

## Technical Description Transit Time Sensors



**Revised Instruction Manual**

Document Revision 08 / 09.02.2026

Original Instruction Manual: German / Rev. 08 / 09.02.2026

**Always use the Technical Description as a unit with the  
Mounting Instruction Transit Time Sensors**

measure analyse optimise

**NIVUS AG**

Burgstrasse 28  
8750 Glarus, Switzerland  
Phone +41 55 6452066  
Fax +41 55 6452014  
info@nivus.ch  
www.nivus.ch

**NIVUS Austria**

Mühlbergstraße 33B  
3382 Loosdorf, Austria  
Phone +43 2754 5676321  
Fax +43 2754 5676320  
austria@nivus.com  
www.nivus.de

**NIVUS Sp. z o.o.**

Ul. Bolesława Krzywoustego 4  
81-035 Gdynia, Poland  
Phone +48 58 7602015  
biuro@nivus.pl  
www.nivus.pl

**NIVUS France SAS**

28 rue de Londres  
75009 Paris, France  
Phone +33 1 89708767  
info@nivus.fr  
www.nivus.fr

**NIVUS Ltd., United Kingdom**

Unit 2D Middlemarch 4020  
Middlemarch Business Park  
Siskin Parkway East  
Coventry, CV3 4SU  
Phone +44 8445 332883  
nivusUK@nivus.com  
www.nivus.co.uk

**NIVUS Middle East (FZE)**

Prime Tower  
Business Bay Dubai  
31<sup>st</sup> floor, office C-3  
P.O. Box: 112037  
Phone +971 4 4580502  
middle-east@nivus.com  
www.nivus.com

**NIVUS Korea Co. Ltd.**

#2301 M-Dong Technopark  
IT Center,  
32 Songdogwahak-ro, Yeonsu-gu,  
INCHEON, Korea 21984  
Phone +82 32 2098588  
Fax +82 32 2098590  
jhkwon@nivuskorea.com  
www.nivuskorea.com

**NIVUS Vietnam**

238/78 Phan Trung Street  
Tan Tien Ward, Bin Hoa City  
Dong Nai Province, Vietnam  
Phone +84 94 2623979  
jhkwon@nivuskorea.com  
www.nivus.com

**NIVUS Africa**

3<sup>rd</sup> floor, block no. 3  
75<sup>th</sup> Fadan Area  
Abo Rawash Industrial Zone  
Giza, Egypt  
Phone +20 2 35393975  
Fax +20 2 35393976  
sales@nivusaf.com  
www.nivus.com

**NIVUS Technologies India Pvt. Ltd.**

5<sup>th</sup> Floor, 502, RMZ KEPPEL  
One Paramount, 10  
Mount Poonamallee High Road  
Porur, Chennai-600116, TN  
Indien  
Tel. +91 44 6923 0047  
india@nivus.com  
www.nivus.in

## Copyrights and Property Rights

The contents of this document including tables and drawings are proprietary to NIVUS GmbH and are not to be reproduced or copied without express written permission.

Violations oblige to compensation.



---

### **Copyright**

*This instruction manual - even in parts - may exclusively be copied or translated in any other way with the express written consent of NIVUS GmbH.*

---

### **Translation**

If the device is sold to a country in the European Economic Area this instruction manual must be translated into the language of the country in which the device is to be used.

Should the translated text be unclear, the original instruction manual (German) must be consulted or a member company of the NIVUS-Group must be contacted for clarification.

### **Copyright**

No part of this publication may be reproduced, transmitted, sold or disclosed without prior permission. All rights reserved.

### **Names**

The use of general descriptive names, trade names, trademarks and the like in this manual does not entitle the reader to assume they may be used freely by everyone. They are often protected registered trademarks even if not marked as such.

## Revision History

Rev.	Modifications	Responsible Editor	Date
08	Chap. "17 Sensor Versions": Type key for sensor NIS- and NIC-CO updated; Chap. "19 Specifications": velocity ranges updated	MoG	09.02.2026
07	NIVUS Addresses updated; Chap. "6 Intended Use": contents "NIS / NIS0 sensors" and "TSP0 sensors" updated; Chap. "15 Sensors in Overview": pipe sensor NIS-RLV200RL removed and wedge sensor NIS-V280KS updated; Chap. "17 Sensor Versions" updated; Chap. "18.1 Sensor types and suitable pipe inside diameters / channel widths": Fig. 18-1 and Fig. 18-3 modified; Chap. "19.1 Flow Velocity Sensors Type NOS-": measurement frequencies updated; Chap. "19.3 Flow Velocity Sensors Type NIS-": operating pressure for wedge sensor modified; Chap. "19.6 Flow Velocity Sensors Type NIC-CO": velocity range and inner pipe diameter updated; Chap. "20 Sensor Dimensions": sensor NIS-V200RL removed and Fig. 20-9 for sensor NIS-V200RT updated; Chap. "28 Accessories (Option)" updated; Chap. "Approvals and Certificates" updated; Minor changes in text and layout	MoG	23.12.2025
06	NIVUS Addresses updated; Chap. "19 Specifications": Accuracy modified; Chap. "Approvals and Certificates" updated	MoG	12.05.2025
05	Addresses updated; Chap. "1 About this Manual", "3 Special safety and Precautionary Measures", "5 Disclaimer", "8 Duties of the Operator", "Delivery, Storage and Transport", "15 Sensors in Overview" and "17 Sensor Versions" updated; Chap. "18 Tips on how to select Sensors" added; Chap. "19 Specifications", "20 Sensor Dimensions", "21 Cable Layouts", "22 Sensor cable", "Maintenance and Cleaning" and "Approvals and Certificates" updated; Various layout changes and updating of graphics	MoG	20.04.2022
04	Address NIVUS France updated; Chap. "4 Warranty" added; Chap. "17 Sensor Versions": product structure for NIS0 and NIC-CO01 updated; Chap. "18.3 Flow Velocity Sensors Type NIS0": internal pipe diameter changed; Chap. "18.4 Flow Velocity Sensors Type TSP0": operation temperature Ex added; Chap. "18.5 Flow Velocity Sensors Type NIC-CO01": operation temperature Ex added; Chap. "23 Dismantling/Disposal"; Note on „EU WEEE-Directive" updated; Chap. "Approvals and Certificates": declarations of conformity updated	MoG	19.03.2020
03	Cover sheet: device versions removed; address NIVUS France updated; revision history added; Chap. "4 Disclaimer" and "5 Intended Use" updated; Sensor NIC0 K1L removed; Chap. "11 Storage", "16 Sensor Versions" and "17.6 Accessories (Option)" updated; declarations of conformity and certificates updated; various minor changes (order of figures changed etc.)	MoG	16.07.2019
02	New sensors incorporated; basic revision of layout (Chap. Safety etc.); various minor changes	MoG	25.08.2017
01	Skipped	--	--
00	New creation on the basis of the German-language instruction manual	DMR	15.10.2012

**Table of Contents**

<b><u>Copyrights and Property Rights</u></b>	<b>3</b>
<b><u>Revision History</u></b>	<b>4</b>
<b><u>Table of Contents</u></b>	<b>5</b>
<b><u>General</u></b>	<b>7</b>
1 About this Manual.....	7
1.1 Applicable Documentation .....	7
1.2 Signs and Definitions used .....	7
<b><u>Safety and Danger Information</u></b>	<b>8</b>
2 Used Symbols and Signal Words.....	8
2.1 Information on the Valuation of Accident Levels.....	8
2.2 Warning Notices on the Device (optional).....	9
3 Special safety and Precautionary Measures.....	9
4 Warranty.....	10
5 Disclaimer.....	10
6 Intended Use .....	10
7 Ex Protection.....	12
8 Duties of the Operator .....	12
9 Requirements for the Personnel .....	13
<b><u>Delivery, Storage and Transport</u></b>	<b>14</b>
10 Scope of Delivery .....	14
11 Inspection upon Receipt.....	14
12 Storage.....	14
13 Transport.....	14
14 Return.....	14
<b><u>Product Description</u></b>	<b>15</b>
15 Sensors in Overview .....	15
15.1 Individual Sensor Overviews.....	16
16 Device ID.....	22
17 Sensor Versions .....	24
18 Tips on how to select Sensors .....	32
18.1 Sensor types and suitable pipe inside diameters / channel widths ....	32
18.2 Required wall thicknesses for clamp-on sensors.....	33
19 Specifications .....	33
19.1 Flow Velocity Sensors Type NOS-.....	33
19.2 Flow Velocity Sensors Type NOS0.....	34
19.3 Flow Velocity Sensors Type NIS- .....	34
19.4 Flow Velocity Sensors Type NIS0.....	35
19.5 Flow Velocity Sensors Type TSP0.....	35
19.6 Flow Velocity Sensors Type NIC-CO.....	36

<b>Installation and Connection</b>	<b>37</b>
20 Sensor Dimensions .....	37
21 Cable Layouts .....	45
22 Sensor cable .....	45
22.1 Cable Extension .....	45
23 Resistance List .....	46
<b>Maintenance and Cleaning</b>	<b>49</b>
24 Maintenance .....	49
24.1 Maintenance Interval .....	49
24.2 Customer Service Information .....	49
25 Cleaning .....	50
26 Dismantling/Disposal .....	50
27 Installation of Spare Parts and Wearing Parts .....	50
28 Accessories (Option) .....	51
<b>Index</b>	<b>52</b>
<b>Approvals and Certificates</b>	<b>53</b>

## General

### 1 About this Manual



#### **Important**

*READ CAREFULLY BEFORE USE.*

*KEEP IN A SAFE PLACE FOR LATER REFERENCE.*

This instruction manual is for the transit time sensors and serves their intended use. The instruction manual is oriented exclusively to qualified expert personnel.

Read this instruction manual carefully and completely prior to installation or connection since it contains relevant information on this product. Observe the notes and particularly follow the warning notes and safety instructions.

If you should have problems to understand information contained within this instruction manual either contact a member company of the NIVUS-Group or one of the distributors for further support. The member companies of the NIVUS-Group cannot be held responsible for damage to persons or material due to incorrectly understood information in this instruction.



#### 1.1 Applicable Documentation

For the installation and operation of the complete system extra instruction manuals or technical descriptions may be required apart from this technical description.

- Instruction manual for the respective flow measurement transmitter/data logger
- Mounting Instruction Transit Time Sensors
- Technical Description Ex Separation Module pXT0 - Transit Time

These manuals are provided with the respective delivery or are available as download on the NIVUS homepage.

#### 1.2 Signs and Definitions used

Representation	Meaning	Remarks
	(Action) Step	Execute action steps; should action steps be numbered observe the specified order of the steps
	Cross-reference	Refers to further or more detailed information
	Documentation Reference	Refers to an accompanying documentation
>Text<	Parameter or menu	Indicates a parameter or a menu that is to be selected or is described

Tab. 1 Structural elements within the manual

## Safety and Danger Information

### 2 Used Symbols and Signal Words

#### 2.1 Information on the Valuation of Accident Levels



The general warning symbol indicates the risk of personal injuries or death. In the text section the general warning symbol is used in combination with the signal words described below.

**DANGER**

**Warning in high degree of risk**



Indicates a high-risk, **imminently** hazardous situation which will result in death or serious injury if not avoided.

**WARNING**

**Warning in medium degree of risk and personal injury**



Indicates a **possible** danger with medium risk which may result in a life-threatening situation or (severe) bodily injury if not avoided.

**CAUTION**

**Warning in personal injury or property damage**



Indicates a **possible** danger with moderate risk which may result in minor or moderate personal injury or property damage if not avoided.

**WARNING**

**Danger by electric voltage**



Indicates a medium-risk, **imminently** hazardous situation caused by electric shock which will result in death or (serious) injury if not avoided.



**Important Note**

Contains information that needs to be highlighted.  
Indicates a potentially harmful situation that may damage the product or something in its environment if not avoided.



**Note**

Contains tips or information.

## 2.2 Warning Notices on the Device (optional)



### **General Warning Notice**

*This symbol refers the operator or user to content in this manual. Consideration of the information contained herein is necessary to maintain the protection provided by the unit for installation and in operation.*



### **Protective earth connection**

*This symbol refers to the protective conductor terminal of the device. Depending on the type of installation, the unit may only be operated with a suitable protective earth connection in accordance with applicable laws and regulations.*

## 3 Special safety and Precautionary Measures

**When working with the NIVUS equipment, the following safety and precautionary measures must be observed and followed generally and at all times. These warnings and notes are not repeated for each description within the document.**

---

### **WARNING**

#### **Check danger due to explosive gases**



*Before starting assembly, installation and maintenance work, be sure to check that all regulations on safety at work have been observed and that there is no possible risk of explosive gases. Use a gas warner for the check.*

*When working in the sewer system, make sure that no electrostatic charge can occur:*

- *Avoid unnecessary movements to reduce the building-up of static charges.*
- *Discharge any static electricity present on your body before you start installing the sensor.*

*Disregarding may result in personal injury or damage to the system.*

---

### **WARNING**

#### **Germ Contamination**



*Due to the frequent use of the sensors in the waste water sector, parts can be contaminated with dangerous germs. Therefore, appropriate precautions must be taken when coming into contact with cables and sensors.*

*Wear protective clothing.*

---

### **WARNING**

#### **Observe Occupational Safety Regulations**



*Installation, mounting, commissioning and maintenance shall only be carried out by appropriately trained personnel. Before beginning mounting works, compliance with all work safety regulations must always be checked.*

*Disregarding may lead to personal injury.*

---

### **WARNING**

#### **Do not disable Safety Devices!**



*It is strictly forbidden to disable the safety devices or to change their mode of operation.*

*Disregarding may result in personal injury or damage to the system.*

---



---

**Commissioning only by qualified Personnel**

*The entire measuring system may only be installed and commissioned by qualified personnel.*

---

## 4 Warranty

The sensors were functionally tested prior to shipping. When used for the intended purpose (see Chap. "6 Intended Use") and in compliance with the technical description, the applicable (see Chap. "1.1 Applicable Documentation") and the safety information and instructions contained therein, no functional restrictions are to be expected and flawless operation should be possible.



Please also refer to the following chapter "5 Disclaimer".



---

**Limitation of Warranty**

*In case of disregarding the safety notes and instructions in this document, the companies of the NIVUS-Group reserve the right to limit the warranty.*

---

## 5 Disclaimer

**The companies of the NIVUS-Group assume no liability**

- for consequential damages resulting from a **change** in this document. The companies of the NIVUS-Group reserve the right to change the contents of the document including this disclaimer without prior notice.
- for personal injury or damage to property resulting from **failure to comply** with the **applicable regulations**. For connection, commissioning and operation of the sensors, all information and higher-level legal regulations of the country (in Germany e.g. the VDE regulations), such as valid Ex regulations as well as the safety and accident prevention regulations applicable to the respective individual case shall be observed.
- for personal injury or damage to property resulting from **improper handling**. For safety and warranty reasons, all work on the equipment that goes beyond the installation and connection-dependent measures may only be carried out by NIVUS personnel or by persons or companies authorised by NIVUS.
- for personal injury or damage to property resulting from the operation of the equipment in a **technically faulty** condition.
- for personal injury or damage to property resulting from **improper use**.
- for personal injury or damage to property resulting from failure to observe the **safety instructions** in this instruction manual.
- for missing or incorrect readings due to **improper installation** and for any consequential damage resulting therefrom.

## 6 Intended Use



---

**Important Note**

*The sensors are intended exclusively for the purpose mentioned below. Any other use beyond this or modification of the sensors without written agreement with the companies of the NIVUS GmbH is considered improper use. The companies of the NIVUS GmbH are not liable for any damage resulting from this.*

*The operator alone bears the risk.*

---

The permissible maximum limit values in Chapter "19 Specifications" must be observed. All cases of use deviating from these limit values, which have not been approved by NIVUS GmbH in writing, are excluded from the liability of the NIVUS-Group.



---

**Note**

*For installation and commissioning observe the following points:*

- *Declaration of Conformity*
  - *Test certificates of the respective authorities*
  - *Applicable national regulations*
- 

**NOS-V2/V3/V4 / NOS0 Sensors**

These sensors are designed to measure the flow velocity in clear, pure water to slightly polluted media in part filled and full pipes, canals or water bodies. Connection preferably to the NivuFlow 650 flow measurement transmitter.

**NOS-V2E/V2S Sensors**

These sensors are designed to measure the flow velocity in clear, pure water to slightly polluted media in full pipes. Connection to NivuFlow 600 and NivuFlow 650 flow measurement transmitters.

**NIS- / NIS0 Sensors**

These sensors are designed to measure the flow velocity in clear, pure water to slightly polluted media in full pipes or rectangular canals.  
Connection to NivuFlow 600 (pipe and wedge sensor) and NivuFlow 650 (wedge sensor only) flow measurement transmitters.

**TSP0 Sensors**

These sensors are designed to measure the flow velocity in clear, pure water to slightly polluted media in full pipes or rectangular canals.  
Connection to the NivuFlow Mobile 600 flow measurement transmitter.

**NIC-CO Sensors**

These sensors are designed to measure the flow velocity in clear, pure water to slightly polluted media in full pipes. These sensors are mounted on the pipe from the outside and have no contact with the medium (contactless measurement). Connection to NivuFlow 600 and NivuFlow Mobile 600 flow measurement transmitters.

## 7 Ex Protection

Some of the sensors described here are designed for use in areas with explosive atmospheres. See also Chap. "17 Sensor Versions".

As a general rule, maintenance and repair shall only be carried out **outside** the Ex area.

### Sensor Approvals

Sensors



II 2G Ex ib IIB T4 Gb (TÜV 12 ATEX 087812)

IECEX TUN 18.0023

#### DANGER



#### **Danger by electrostatic Discharge**

*When working in the sewer system, make sure that no electrostatic charge can occur:*

- *Avoid unnecessary movements to reduce the building-up of static charges.*
- *Discharge any static electricity present on your body before you start installing the sensor.*

*Disregarding may result in personal injury or damage to the system.*



#### **Validity of the Ex Approval**

*The Ex approval is only valid in conjunction with the corresponding marking on the nameplate of the sensors.*



#### **Declarations of Conformity and Test Certificates**

*For installation and commissioning, the EU declarations of conformity and test certificates of the approving body must be strictly observed.*

## 8 Duties of the Operator



#### **Strictly observe and comply with guidelines and requirements**

*In the EEA (European Economic Area), the national transposition of the Framework Directive (89/391/EEC) as well as the associated individual directives and, in particular, the Directive (2009/104/EC) concerning the minimum safety and health requirements for the use of work equipment by workers at work, as amended, must be observed and complied with.*

*In Germany, the Ordinance on Industrial Safety and Health must be complied with.*

Obtain the local operating licence and observe the associated conditions. In addition, you must comply with environmental protection requirements and local legal requirements for the following:

- Safety of personnel (accident prevention regulations)
- Safety of work equipment (protective equipment and maintenance)
- Product Disposal (Waste Management Act)
- Materials Disposal (Waste Management Act)
- Cleaning (Cleaning Agents and Disposal)

## **Connections**

As the operator, before activating the measurement system, make sure that the local regulations (e.g. for the electrical connection) have been observed during installation and commissioning.

## **Keep the Instruction Manual for future Reference**

Keep the instruction manual in a safe place and ensure that it is always available and can be consulted by the user of the product.

## **Hand over the Instruction Manual**

When selling the sensors, this manual must be handed over with it. The manual is part of the standard delivery.

## **9 Requirements for the Personnel**

Installation, commissioning and maintenance may only be carried out by personnel who fulfil the following conditions:

- Qualified personnel with appropriate training
- Authorisation by plant operator



### **Qualified Personnel**

*in the sense of these instructions or the warnings on the product itself are persons who are familiar with the installation, assembly, commissioning and operation of the product and who have the qualifications appropriate to their job, such as*

- I. training and instruction or authorisation to switch circuits and devices/systems on and off, to earth and to label them in accordance with the standards of safety technology.*
  - II. Training or instruction in accordance with safety technology standards in maintenance and use of appropriate safety equipment.*
  - III. First Aid Training*
-

## Delivery, Storage and Transport

### 10 Scope of Delivery

The standard delivery of the transit time sensors comprises:

- Transit time sensors (quantity and type according to delivery documents)
- Technical description (with EU Declarations of Conformity and respective Ex Certificates) including all information required for operation of the sensors (printed copy or link to the NIVUS download centre)
- Mounting instructions for transit time sensors (printed copy or link to the NIVUS download centre)

Check additional accessories according to the order against the delivery note.

### 11 Inspection upon Receipt

Check the delivery for completeness and apparent intactness immediately after receipt. Report any transport damage immediately to the delivering freight carrier. Also send a written report to NIVUS GmbH in Eppingen.

Incomplete deliveries must be addressed in writing within two weeks to your responsible representative or directly to the head office in Eppingen.



---

**Observe the two-week deadline**

*Complaints received later will not be recognised.*

---

### 12 Storage

Observe the minimum and maximum values for external conditions such as temperature and humidity according to Chapter "19 Specifications".

Protect the instrument from corrosive or organic solvent vapours, radioactive radiation and strong electromagnetic radiation.

### 13 Transport

Protect the sensors from strong impacts, shocks, jolts or vibrations. Transport must be carried out in the original packaging.

Otherwise, the same conditions apply with regard to external influences as for storage (see Chap. "12 Storage").

### 14 Return

In the event of a return, send the sensor to NIVUS GmbH in Eppingen carriage paid and in the original packaging.

Items that have not been sufficiently franked will not be accepted!

In general, a return note (incl. RMA return number) must be requested from the NIVUS customer service before returning the goods. Without this RMA number, the incoming goods cannot be assigned accordingly.

➡ See Chap. "24.2 Customer Service Information".

## Product Description

### 15 Sensors in Overview

The sensors shown are designed for connection to NIVUS transmitters. They are always matched as pairs ex works and must be used/connected accordingly.

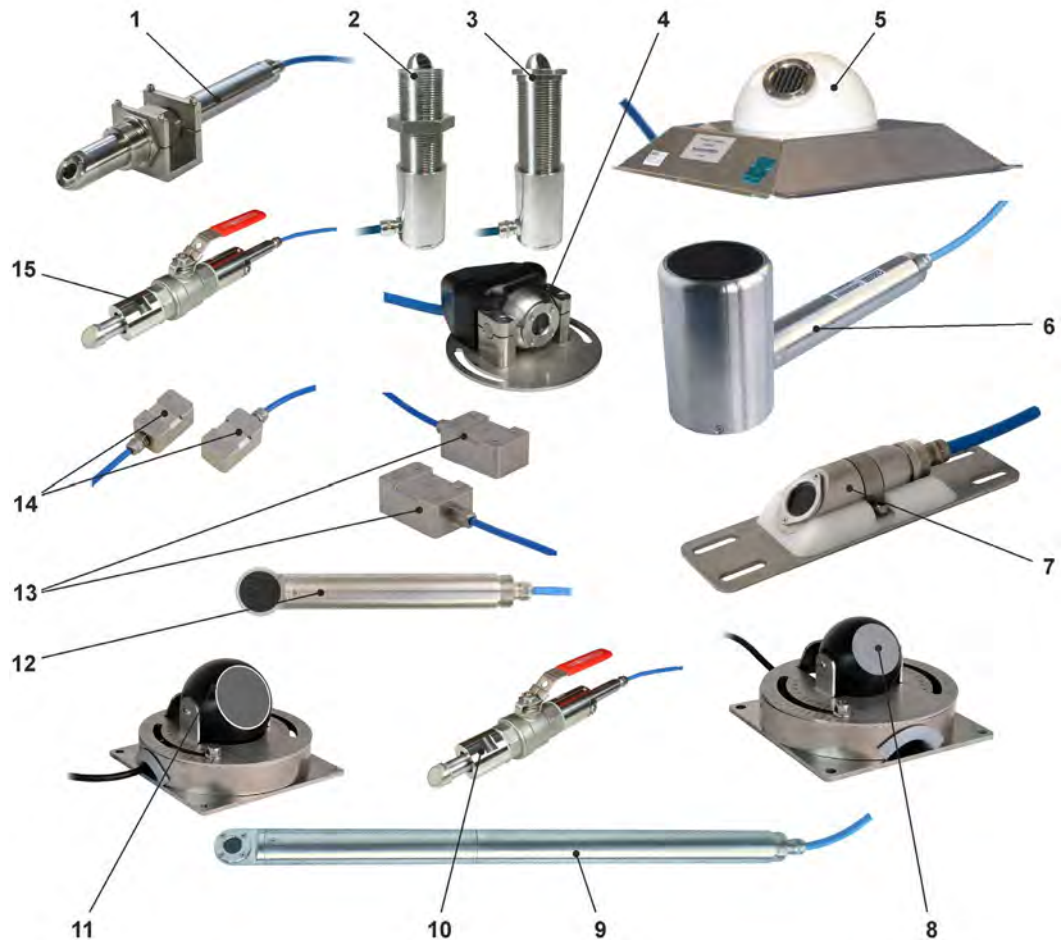

- 1 Flow velocity pipe sensor Type NIS-V200RT (1 MHz)
- 2 Flow velocity screw-in sensor Typ NOS-V2E (1 MHz)
- 3 Flow velocity plug-in sensor Type NOS-V2S (1 MHz)
- 4 Flow velocity ball head sensor Type NOS-V20BS (1 MHz) (shown without fastening plate and nuts)
- 5 Flow velocity hemisphere sensor Type NOS-V30BS (1 MHz)
- 6 Flow velocity rod sensor Type NOS-V40 (200 kHz)
- 7 Flow velocity wedge sensor Type NIS-V280KS (1 MHz)
- 8 Flow velocity ball sensor Type NOS0H0V500 (500 kHz)
- 9 Flow velocity rod sensor Type NOS-V200 (1 MHz)
- 10 Flow velocity pipe sensor Type TSP0V200 (1 MHz)
- 11 Flow velocity ball sensor Type NOS0H0V200 (200 kHz)
- 12 Flow velocity rod sensor Type NOS-V300 (1 MHz)
- 13 Clamp-on sensor pair Type NIC-CO50 (500 kHz)
- 14 Clamp-on sensor pair Type NIC-CO01 (1 MHz)

### 15 Flow velocity pipe sensor Type NIS0V200RL (1 MHz)

**Fig. 15-1 Overview of sensors**

#### 15.1 Individual Sensor Overviews



- 1 Sensor for transit time difference measurement (use as pairs)
- 2 Sensor body
- 3 Sensor extension (optional)
- 4 Sensor cable

**Fig. 15-2 Rod sensor Type NOS-V200**

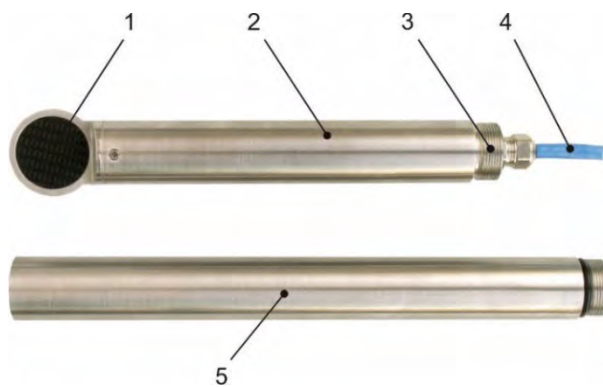

- 1 Sensor for transit time difference measurement (use as pairs)
- 2 Sensor body
- 3 Thread for screwing on the extension
- 4 Sensor cable
- 5 Sensor extension (optional)

**Fig. 15-3 Rod sensor Type NOS-V300**

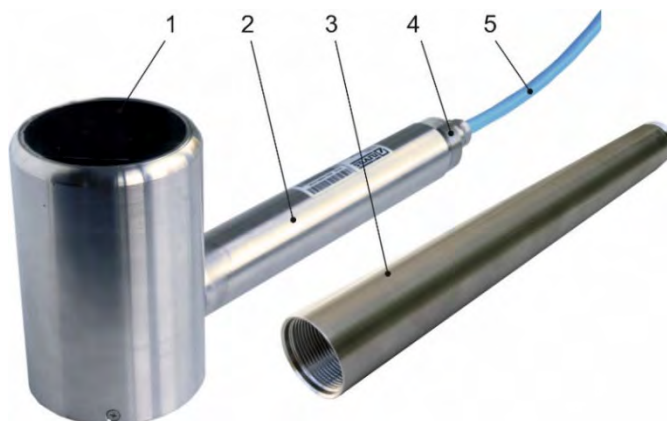

- 1 Sensor for transit time difference measurement (use as pairs)
- 2 Sensor body

- 3 Sensor extension (optional)
- 4 Thread for screwing on the extension
- 5 Sensor cable

**Fig. 15-4 Rod sensor Type NOS-V40**

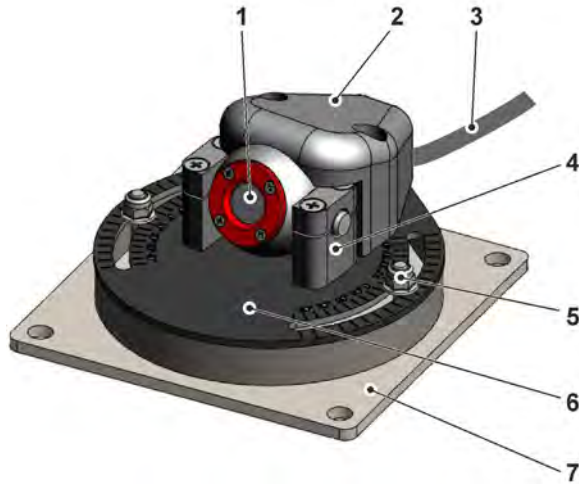

- 1 Sensor head (swivelling) (sensor for transit time difference measurement; use as pairs)
- 2 Cover
- 3 Sensor cable
- 4 Clamping element
- 5 Nuts for aligning/locking the sensor holder
- 6 Sensor holder (rotatable/adjustable)
- 7 Fastening plate for ball sensors

**Fig. 15-5 Ball head sensor Type NOS-V20BS**

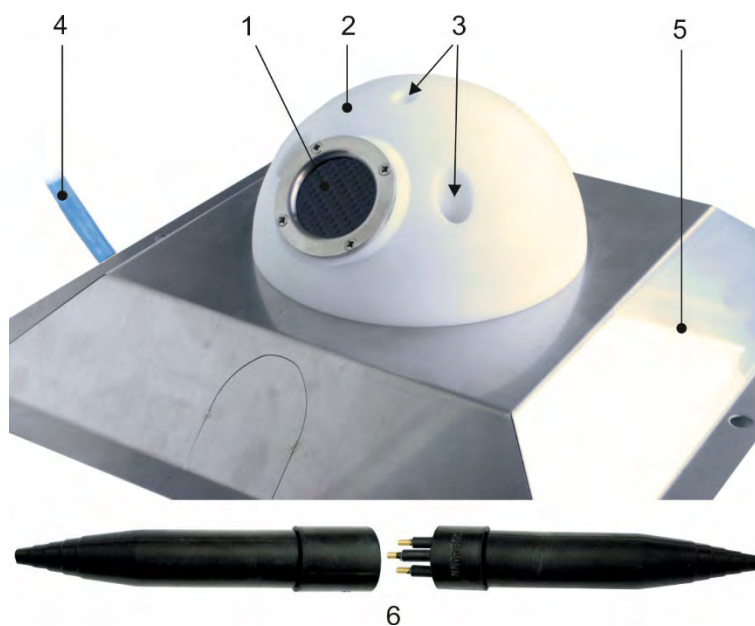

- 1 Sensor for transit time difference measurement (use as pairs)
- 2 Sensor body

- 3 Alignment screws
- 4 Sensor cable
- 5 Holder for hemisphere sensors (optional)
- 6 Underwater plug connector (optional)

**Fig. 15-6 Hemisphere sensor Type NOS-V30BS**



- 1 Sensor for transit time difference measurement (swivelling) (use as pairs)
- 2 Fastening plate for ball sensors
- 3 Sensor holder (rotatable/adjustable)
- 4 Nuts for aligning/locking the sensor holder
- 5 Sensor clamping
- 6 Sensor cable

**Fig. 15-7 Ball sensor Type NOS0H0V200**

➡ Associated standard holding device see Chap. "28 Accessories (Option)".



- 1 Sensor for transit time difference measurement (swivelling) (use as pairs)
- 2 Fastening plate for ball sensors
- 3 Sensor holder (rotatable/adjustable)
- 4 Nuts for aligning/locking the sensor holder
- 5 Sensor clamping

## 6 Sensor cable

---

**Fig. 15-8 Ball sensor Type NOS0H0V500**

➡ Associated standard holding device see Chap. "28 Accessories (Option)".

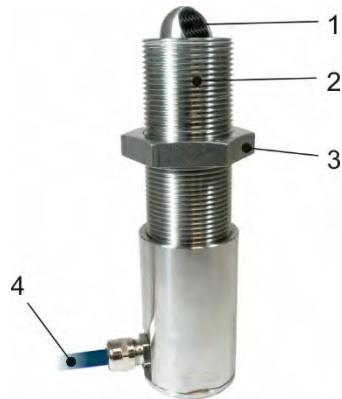

- 1 Sensor for transit time difference measurement (use as pairs)
- 2 Sensor body
- 3 Nut for alignment and fixing
- 4 Sensor cable

---

**Fig. 15-9 Screw-in sensor Type NOS-V2E**

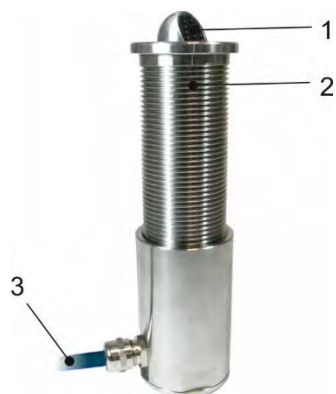

- 1 Sensor for transit time difference measurement (use as pairs)
- 2 Sensor body
- 3 Sensor cable

---

**Fig. 15-10 Plug-in sensor Type NOS-V2S**

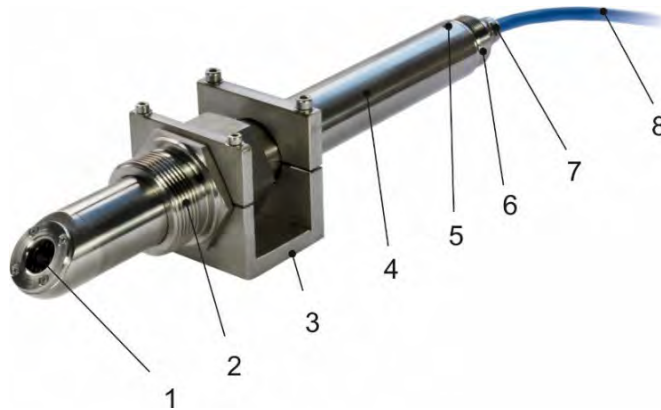

- 1 Sensor for transit time difference measurement (use as pairs)
- 2 Sensor screw connection (movable)
- 3 Fastening element
- 4 Sensor body
- 5 Thread for screwing in the alignment aid, screw M4
- 6 Thread for screwing on the extension
- 7 Cable gland
- 8 Sensor cable

**Fig. 15-11 Pipe sensor Type NIS-V200RT**

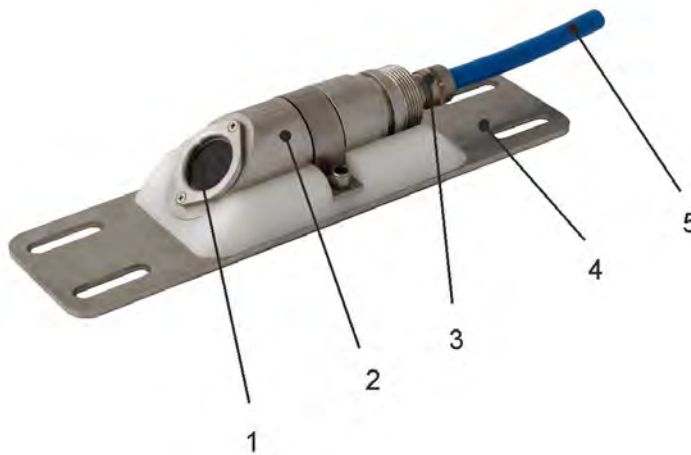

- 1 Sensor for transit time difference measurement (use as pairs)
- 2 Sensor body
- 3 Cable gland
- 4 Mounting plate
- 5 Sensor cable

**Fig. 15-12 Wedge sensor Type NIS-V280KS**

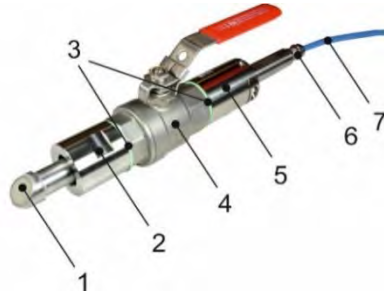

- 1 Sensor head (sensor for transit time difference measurement; use as pairs)
- 2 Welding Nozzle
- 3 Flat gasket
- 4 Ball Valve
- 5 Sealing and securing element
- 6 Cable gland
- 7 Sensor cable

---

**Fig. 15-13 Pipe sensor Type NIS0V200**

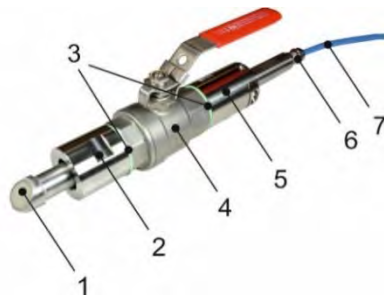

- 1 Sensor head (sensor for transit time difference measurement; use as pairs)
- 2 Welding Nozzle
- 3 Flat gasket
- 4 Ball Valve
- 5 Sealing and securing element
- 6 Cable gland
- 7 Sensor cable

---

**Fig. 15-14 Pipe sensor Type TSP0V200**



- 1 Sensor pair for transit time difference measurement (use as pair)
- 2 Sensor cable

---

**Fig. 15-15 Clamp-on sensors Type NIC-CO01**

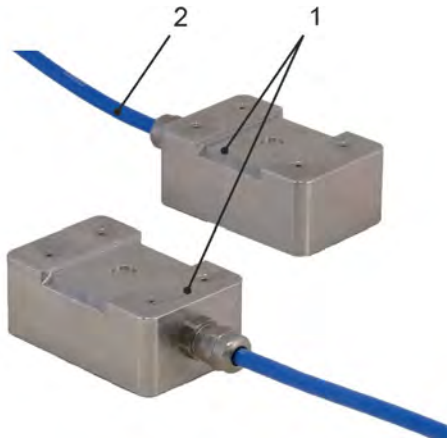

- 1 Sensor pair for transit time difference measurement (use as pair)
- 2 Sensor cable

**Fig. 15-16 Clamp-on sensors Type NIC-CO50**

## 16 Device ID

The information in this technical description only applies to the sensor types indicated on the title page.

The nameplates are located at the entrance of the cable into the sensor body as well as at the end of the cable. They are protected against weathering and abrasion by means of a transparent heat shrink tubing and contain the following information:

- Name and address NIVUS GmbH
- CE label
- Marking of the series and type with article number and serial number
- Year of manufacture: the first four digits of the serial number refer to the year of manufacture and the week number (2203.....)
- Ex Protection Label
- Ambient conditions in operation

It is important for all queries and spare parts orders that the article number and serial number of the respective sensors are specified correctly. This is the only way to ensure proper and fast processing.



**Fig. 16-1 Nameplate flow velocity sensor non-Ex (example Type NOS)**



Fig. 16-2 Ex nameplates flow velocity sensor Type NIS-V2 (additional)

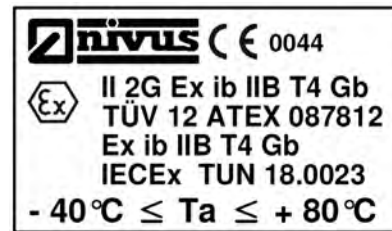

Fig. 16-3 Ex nameplates flow velocity sensor Type NIS0V2 (additional)



Fig. 16-4 Ex nameplates flow velocity sensor Type TSP0 (additional)

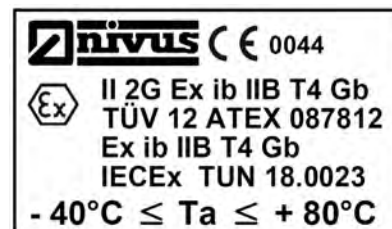

Fig. 16-5 Ex nameplates clamp-on sensor Type NIC-CO01 (additional)

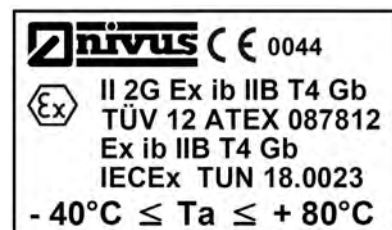

Fig. 16-6 Ex nameplates clamp-on sensor Type NIC-CO50 (additional)



**Check nameplates**

Check by means of the nameplates whether the supplied sensor corresponds with your order.

### 17 Sensor Versions

The sensors are manufactured in various designs and also differ in cable lengths, cable connections and various special designs and materials.

The article number is located at the entrance of the cable into the sensor body as well as at the end of the cable on a nameplate applied to the cable sheath. These are protected against weathering and abrasion by means of a transparent heat shrink tubing. In addition, the connection terminal designation of the sensor and a note are attached to the end of the sensor cable.

Sensors assembled as pairs are matched to each other. This individual offset is noted on the respective cable labels.

NOS-	Design/Type
	<b>V2005</b> Rod sensors; installation tube length 500 mm, $\varnothing$ 35 mm; sensor head (made of 1.4571) with CFK sensor face ( $\varnothing$ 20 mm) for 1 MHz; for installation in flowing waters with path lengths up to 6 m
	<b>V3005</b> Rod sensors; installation tube length 500 mm, $\varnothing$ 35 mm; sensor head (made of 1.4571) with CFK sensor face ( $\varnothing$ 40 mm) for 1 MHz; for installation in flowing waters with path lengths up to 10 m
	<b>V4005</b> Rod sensors; installation tube length 500 mm, $\varnothing$ 35 mm; sensor head (made of 1.4571) with CFK sensor face ( $\varnothing$ 65 mm) for 200 kHz
	<b>V20BS</b> Ball head sensor, adjustable; POM with GFK sensor face 1.4571 ( $\varnothing$ 20 mm); for 1 MHz; flow-optimised
	<b>V30BS</b> Hemisphere sensors; POM with CFK sensor face 1.4571 ( $\varnothing$ 40 mm); for 1 MHz; flow-optimised
	<b>V30BX</b> Hemisphere sensors; POM with CFK, straight sensor head, sensor face 1.4571 ( $\varnothing$ 40 mm); for 1 MHz; flow-optimised
	<b>Pressure Level</b> <b>L</b> 1.2 bar
	<b>Path Position</b> <b>1</b> Path position 45° against flow direction (recommended setup angle)
	<b>ATEX Approval</b> <b>0</b> None
	<b>Cable length</b> <b>10</b> 10 m pre-assembled <b>20</b> 20 m pre-assembled <b>30</b> 30 m pre-assembled <b>40</b> 40 m pre-assembled <b>50</b> 50 m pre-assembled <b>60</b> 60 m pre-assembled <b>70</b> 70 m pre-assembled <b>80</b> 80 m pre-assembled <b>90</b> 90 m pre-assembled <b>99</b> 100 m pre-assembled
	<b>Sensor Connection</b> <b>A</b> For connection to NivuFlow 600/650 transmitters via underwater plug connection (only for Type V30B)

						<b>B</b> For connection to NivuFlow 600/650 transmitters via underwater plug connection (only for Type V30B) using NFE extension modules <b>K</b> For connection to NivuFlow 600/650 transmitters or to BSL0 SPT xx overvoltage protection <b>Z</b> For connection to NivuFlow 600/650 transmitters using NFE extension modules
<b>NOS-</b>		<b>L</b>	<b>1</b>	<b>0</b>		

**Tab. 2** Type key for ultrasonic sensors Type NOS

<b>NOS-</b>	<b>Design/Type</b>					
	<b>V2E00</b>	Screw-in sensors 1¼" for installation using a welding sleeve (sensor installation only possible from outside)				
	<b>V2S00</b>	Plug-in sensors for installation in duct hole (sensor installation only possible from inside)				
		<b>Pressure Level</b>				
		<b>H</b>	80 bar			
			<b>Path Position</b>			
			<b>A</b>	45°		
			<b>B</b>	Multi-path system 18°; for setup according to IEC60041; upon request		
			<b>C</b>	Multi-path system 30°; for setup according to IEC60041; upon request		
			<b>D</b>	Multi-path system 54°; for setup according to IEC60041; upon request		
			<b>X</b>	Special position		
				<b>ATEX Approval</b>		
			<b>0</b>	None		
				<b>Cable length</b>		
			<b>10</b>	10 m pre-assembled		
			<b>20</b>	20 m pre-assembled		
			<b>30</b>	30 m pre-assembled		
			<b>40</b>	40 m pre-assembled		
			<b>50</b>	50 m pre-assembled		
			<b>60</b>	60 m pre-assembled		
			<b>70</b>	70 m pre-assembled		
			<b>80</b>	80 m pre-assembled		
			<b>90</b>	90 m pre-assembled		
			<b>99</b>	100 m pre-assembled		
				<b>Sensor Connection</b>		
			<b>K</b>	For connection to NivuFlow 600/650 transmitters or to BSL0 SPT xx overvoltage protection		
			<b>Z</b>	For connection to NivuFlow 600/650 transmitters using NFE extension modules		
<b>NOS-</b>		<b>H</b>		<b>0</b>		

Tab. 3 Type key for screw-in/plug-in sensors Type NOS

NOS0	Design/Type
	<p><b>H0 V500</b> 500 kHz Ultrasonic ball sensor, temperature range: -20 °C bis 50 °C; for flow velocity detection using transit time difference; for part filled and full pipes and shapes, open canals and water bodies; incl. mounting holder for sensor fastening on abutments; material: 1.4571/AISI 316 Ti</p> <p><b>H0 V200</b> 200 kHz Ultrasonic ball sensor, temperature range: -20 °C bis 50 °C; for flow velocity detection using transit time difference; for part filled and full pipes and shapes, open canals and water bodies; incl. mounting holder for sensor fastening on abutments; material: 1.4571/AISI 316 Ti; width: 92 mm</p> <p><b>ATEX Approval</b></p> <p><b>0</b> None</p> <p><b>Cable length</b></p> <p><b>10</b> 10 m pre-assembled</p> <p><b>20</b> 20 m pre-assembled</p> <p><b>30</b> 30 m pre-assembled</p> <p><b>40</b> 40 m pre-assembled</p> <p><b>50</b> 50 m pre-assembled</p> <p><b>60</b> 60 m pre-assembled</p> <p><b>70</b> 70 m pre-assembled</p> <p><b>80</b> 80 m pre-assembled</p> <p><b>90</b> 90 m pre-assembled</p> <p><b>99</b> 100 m pre-assembled</p> <p><b>Sensor Connection</b></p> <p><b>K</b> For connection to NivuFlow 600 transmitter or to BSL0 SPT xx overvoltage protection</p> <p><b>Z</b> For connection to NivuFlow 600 transmitter using NFE extension modules</p>
<b>NOS0</b>	<b>0</b>

Tab. 4 Type key for ultrasonic sensors (ball sensors) Type NOS0

NIS-	Design
	<b>V200</b> Pipe sensor <b>Type</b> <b>RT</b> Pipe sensors 1½"; pressure up to max. 16 bar; 1.4571/AISI 316 Ti with CFK sensor face
	<b>V280</b> Wedge Sensor <b>Type</b> <b>KS</b> Wedge sensors 1.4571/AISI 316 Ti with alignment aid; pressure up to max. 10 bar <b>Approval</b> <b>0</b> None <b>2</b> Drinking water approval according to WRAS (BS6920) (only for V200 design pipe sensors) <b>E</b> ATEX Approval Zone 1 (max. cable length 20 m) <b>Cable length</b> <b>10</b> 10 m pre-assembled <b>20</b> 20 m pre-assembled <b>30</b> 30 m pre-assembled <b>40</b> 40 m pre-assembled <b>50</b> 50 m pre-assembled <b>60</b> 60 m pre-assembled <b>70</b> 70 m pre-assembled <b>80</b> 80 m pre-assembled <b>90</b> 90 m pre-assembled <b>99</b> 100 m pre-assembled <b>Sensor Connection</b> <b>K</b> For connection to NivuFlow 600 transmitter or to BSL0 SPT xx overvoltage protection <b>Z</b> For connection to NivuFlow 600 transmitter using NFE extension modules <b>Variants</b> <b>0</b> Wedge sensor <b>2</b> Pipe length 200 mm, for Type RT <b>3</b> Pipe length 300 mm (with stop ball valve) <b>X</b> Special pipe length, only for Type RT
NIS-	

**Tab. 5** Type key for ultrasonic sensors Type NIS

<b>NIS0</b>	<b>Design</b>					
	<b>V200</b>	Pipe sensor				
	<b>Type</b>					
	<b>RL</b>	Pipe sensors 1" with 1" stop ball valve and welding nozzle (stainless steel), 1 MHz; pressure up to max. 16 bar; for use in DN100...DN2500				
	<b>ATEX Approval</b>					
	<b>0</b>	None				
	<b>E</b>	Zone 1 (max. permissible cable length 20 m)				
	<b>Cable length</b>					
	<b>10</b>	10 m pre-assembled				
	<b>20</b>	20 m pre-assembled				
	<b>30</b>	30 m pre-assembled				
	<b>40</b>	40 m pre-assembled				
	<b>50</b>	50 m pre-assembled				
	<b>60</b>	60 m pre-assembled				
	<b>70</b>	70 m pre-assembled				
	<b>80</b>	80 m pre-assembled				
	<b>90</b>	90 m pre-assembled				
	<b>99</b>	100 m pre-assembled				
	<b>Sensor Connection</b>					
	<b>K</b>	For connection to NivuFlow 600 transmitter or to BSL0 SPT xx overvoltage protection				
	<b>Z</b>	For connection to NivuFlow 600 transmitter using NFE extension modules				
	<b>Pipe length</b>					
	<b>3</b>	300 mm				
<b>NIS0</b>	<b>V200</b>	<b>RL</b>				<b>3</b>

Tab. 6 Type key for ultrasonic sensors Type NIS0

<b>TSP0</b>	<b>Design</b>					
	<b>V200</b>	Pipe sensor				
	<b>Type</b>					
	<b>RL</b>	Pipe sensors 1" with 1" stop ball valve and welding nozzle (stainless steel), 1 MHz; pressure up to max. 16 bar; for use in DN100...DN2500				
	<b>ATEX Approval</b>					
	<b>0</b>	None				
	<b>E</b>	Zone 1 (max. permissible cable length 20 m)				
	<b>Cable length</b>					
	<b>10</b>	10 m pre-assembled				
	<b>15</b>	15 m pre-assembled				
	<b>20</b>	20 m pre-assembled				
	<b>30</b>	30 m pre-assembled				
	<b>40</b>	40 m pre-assembled				
	<b>50</b>	50 m pre-assembled				
	<b>60</b>	60 m pre-assembled				
	<b>70</b>	70 m pre-assembled				
	<b>80</b>	80 m pre-assembled				
	<b>90</b>	90 m pre-assembled				
	<b>99</b>	100 m pre-assembled				
	<b>Sensor Connection</b>					
	<b>M</b>	Connection to NivuFlow Mobile 600 transmitter				
	<b>Pipe length</b>					
	<b>3</b>	300 m				
<b>TSP0</b>	<b>V200</b>	<b>RL</b>			<b>M</b>	<b>3</b>

**Tab. 7 Type key for ultrasonic sensors Type TSP0**

NIC-	Type
	<p><b>CO01</b> Clamp-On Sensor Pair (1 MHz); DN50 - 2500; made of stainless steel/PEEK; measurement range <math>\pm 25</math> m/s; temperature range -40...+80 °C</p> <p><b>CO50</b> Clamp-On Sensor Pair (500 kHz); DN500 – 6000; made of stainless steel/PEEK; measurement range <math>\pm 25</math> m/s; temperature range -40...+80 °C</p> <p><b>ATEX Approval</b></p> <p><b>0</b> None</p> <p><b>E</b> Zone 1 (max. permissible cable length 20 m)</p> <p><b>Cable length</b></p> <p><b>07</b> 7 m pre-assembled</p> <p><b>10</b> 10 m pre-assembled</p> <p><b>20</b> 20 m pre-assembled</p> <p><b>30</b> 30 m pre-assembled</p> <p><b>40</b> 40 m pre-assembled</p> <p><b>50</b> 50 m pre-assembled</p> <p><b>Sensor Connection</b></p> <p><b>K</b> For connection to NivuFlow 600 transmitter or to BSL0 SPT xx overvoltage protection</p> <p><b>M</b> For connection to NivuFlow Mobile 600 transmitter, with plug connector</p> <p><b>Z</b> For connection to NivuFlow 600 transmitter using NFE extension modules</p>
<b>NIC-</b>	

Tab. 8 Type key for clamp-on sensors Type NIC-CO

## 18 Tips on how to select Sensors

### 18.1 Sensor types and suitable pipe inside diameters / channel widths

The following graphics quickly show which sensor types can be used with the common pipe inside diameters / channel widths. From the minimum technically required width to the maximum possible width (also with recommended range).

For the actual sensor selection, however, the type and nature of the overall application must always be taken into account.



Fig. 18-1 NOS-/NOS0 (rod, (hemisphere) ball sensor) and suitable channel widths

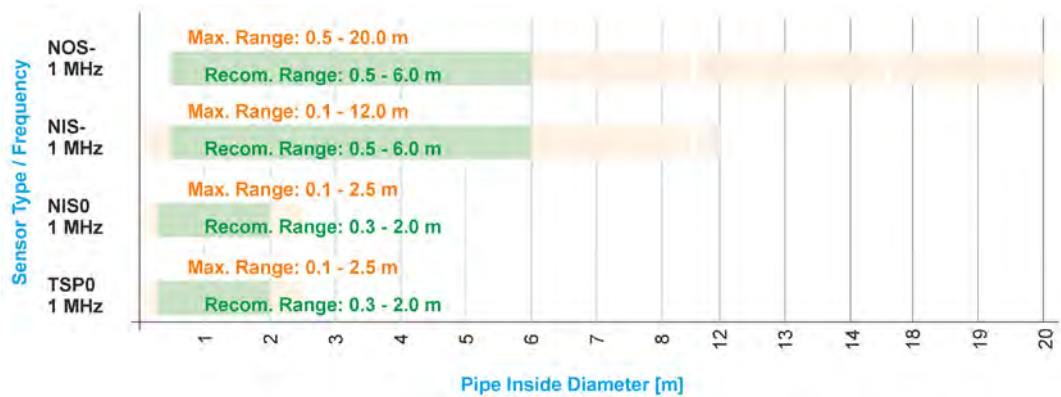

Fig. 18-2 NOS-/NIS-/NIS0 (screw-in, plug-in, pipe sensor) and suitable pipe inside diameters

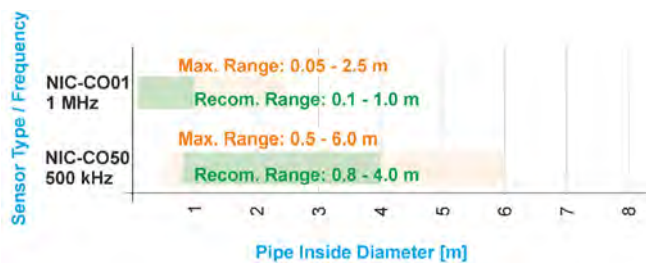

Fig. 18-3 NIC-CO (clamp-on sensor) and suitable pipe inside diameters

**18.2 Required wall thicknesses for clamp-on sensors**

Sensor	Minimum Wall Thickness
NIC-CO01	2 mm
NIC-CO50	5 mm

**Tab. 9 Required wall thicknesses**

**19 Specifications**

**19.1 Flow Velocity Sensors Type NOS-**

<b>Measurement Principle</b>	Ultrasonic Transit Time Difference
<b>Measurement Frequencies</b>	1 MHz, 200 kHz
<b>Velocity Range</b>	±25 m/s Minimum flow velocity: 0.01 m/s
<b>Channel Widths</b>	0.5...200 m; other channel widths upon request
<b>Accuracy</b>	- Rod sensor / (Hemisphere) Ball sensor: Flow Velocity ( $v_{average}$ ) within path ±0.1 % of measurement value - Plug-in sensor / screw-in sensor: Volume flow (Q): ±0.5 % of measured value with process calibration
<b>Protection</b>	IP68
<b>Operation Temperature</b>	-40 °C...+50 °C
<b>Storage Temperature</b>	-40 °C...+70 °C
<b>Cable length</b>	10/20/30/40/50/60/70/80/90/100 m; Extension option: Sensors can be connected to an extension module, cable length between extension module and transmitter max. 200 m
<b>Cable Design</b>	Continuous assembled cable; Pre-assembled cable with underwater coupling (optional for NOS-V30B)
<b>Cable Type</b>	Twinax 2x AWG 20; PUR
<b>Outside Cable Diameter</b>	8.5 mm
<b>Sensor Types</b>	- Rod sensor - (Hemisphere) Ball sensor - Plug-in sensor/screw-in sensor
<b>Medium contacting Materials</b>	- Rod sensor/plug-in sensor/screw-in sensor: stainless steel 1.4571/AISI 316 Ti, CFK (Carbon), Viton® - Hemisphere: stainless steel 1.4571/AISI 316 Ti, CFK (Carbon), POM, PUR, Neoprene with underwater coupling - Ball head sensor: stainless steel 1.4571/AISI 316 Ti, CFK (Carbon), POM - Cable: PUR
<b>Temperature Measurement / Sound Velocity Measurement</b>	
<b>Measurement Range</b>	0 °C...+60 °C
<b>Measurement Error</b>	±1 K

**Tab. 10 Specifications Type NOS-**

### 19.2 Flow Velocity Sensors Type NOS0

<b>Measurement Principle</b>	Ultrasonic Transit Time Difference
<b>Measurement Frequencies</b>	500 kHz, 200 kHz
<b>Velocity Range</b>	±25 m/s Minimum flow velocity: 0.01 m/s
<b>Channel Widths</b>	0.5...200 m; other channel widths upon request
<b>Accuracy</b>	Flow Velocity ( $v_{\text{average}}$ ) within path ±0.1 % of measurement value
<b>Protection</b>	IP68
<b>Operation Temperature</b>	-40 °C...+50 °C
<b>Storage Temperature</b>	-40 °C...+70 °C
<b>Cable length</b>	10/20/30/40/50/60/70/80/90/100 m; Extension option: Sensors can be connected to an extension module, cable length between extension module and transmitter max. 200 m
<b>Cable Design</b>	Continuous assembled cable
<b>Cable Type</b>	Twinax 2x AWG 20; PUR
<b>Outside Cable Diameter</b>	8.5 mm
<b>Sensor Types</b>	Ball sensor
<b>Medium contacting Materials</b>	- Ball head sensor: stainless steel 1.4571/AISI 316 Ti, CFK (Carbon), POM - Cable: PUR
<b>Temperature Measurement / Sound Velocity Measurement</b>	
<b>Measurement Range</b>	0 °C...+60 °C
<b>Measurement Error</b>	±1 K

Tab. 11 Specifications Type NOS0

### 19.3 Flow Velocity Sensors Type NIS-

<b>Measurement Principle</b>	Ultrasonic Transit Time Difference
<b>Measurement Frequency</b>	1 MHz
<b>Velocity Range</b>	±25 m/s Minimum flow velocity: 0.01 m/s
<b>Internal Pipe Diameter</b>	0.1...12 m (DN100...DN12000)
<b>Accuracy</b>	- Pipe sensor: Volume flow (Q): ±0.5 % of measured value with process calibration - Wedge sensor: Flow Velocity ( $v_{\text{average}}$ ) within path ±0.1 % of measurement value
<b>Protection</b>	IP68
<b>Ex Approval</b>	ATEX / IECEx Zone 1 (optional); see Chap. "7 Ex Protection"
<b>Operation Temperature</b>	-40 °C...+50 °C
<b>Storage Temperature</b>	-40 °C...+80 °C
<b>Cable length</b>	10/20/30/40/50/60/70/80/90/100 m; Extension option: Sensors can be connected to an extension module, cable length between extension module and transmitter max. 200 m
<b>Cable Type</b>	Twinax 2x AWG 20; PUR
<b>Outside Cable Diameter</b>	8.5 mm

<b>Sensor Types</b>	- Pipe sensor incl. fastening element for installation using nozzle on pipe - Wedge sensor with base plate for fastening on channel wall
<b>Medium contacting Materials</b>	- Pipe sensor: stainless steel 1.4571/AISI 316 Ti, CFK (Carbon), NBR, HDPE - Wedge sensor: stainless steel 1.4571/AISI 316 Ti, CFK (Carbon) - Cable: PUR
<b>Operation Pressure</b>	- Pipe sensor: max. 16 bar (with fastening element) - Wedge sensor: max. 10 bar
<b>Temperature Measurement using Sound Velocity</b>	
<b>Measurement Range in the Medium</b>	0 °C...+60 °C
<b>Measurement Uncertainty</b>	±1 K

Tab. 12 Specifications Type NIS-

#### 19.4 Flow Velocity Sensors Type NIS0

<b>Measurement Principle</b>	Ultrasonic Transit Time Difference
<b>Measurement Frequency</b>	1 MHz
<b>Velocity Range</b>	±25 m/s Minimum flow velocity: 0.01 m/s
<b>Internal Pipe Diameter</b>	0.1...2.5 m (DN100...DN2500)
<b>Accuracy</b>	Volume flow (Q): ±0.5 % of measured value with process calibration
<b>Protection</b>	IP68
<b>Ex Approval</b>	ATEX / IECEx Zone 1 (optional); see Chap. "7 Ex Protection"
<b>Operation Temperature</b>	-20 °C ≤ Ta ≤ +50 °C Ex Version: -40 °C ≤ Ta ≤ 80 °C
<b>Storage Temperature</b>	-40 °C...+80 °C
<b>Cable length</b>	10/20/30/40/50/30/70/80/90/100 m
<b>Cable Type</b>	Twinax 2x AWG 20
<b>Outside Cable Diameter</b>	8.5 mm
<b>Sensor Types</b>	Pipe sensor incl. fastening element for installation using nozzle on pipe
<b>Medium contacting Materials</b>	Pipe sensor: stainless steel 1.4571/AISI 316 Ti, CFK (Carbon), NBR, HDPE
<b>Operation Pressure</b>	Pipe sensor: max. 16 bar (with fastening element) (others upon request)
<b>Temperature Measurement using Sound Velocity</b>	
<b>Measurement Range in the Medium</b>	0 °C...+60 °C
<b>Measurement Uncertainty</b>	±1 K

Tab. 13 Specifications Type NIS0

#### 19.5 Flow Velocity Sensors Type TSP0

<b>Measurement Principle</b>	Ultrasonic Transit Time Difference
<b>Measurement Frequency</b>	1 MHz
<b>Velocity Range</b>	±25 m/s Minimum flow velocity: 0.01 m/s
<b>Internal Pipe Diameter</b>	0.1...2.5 m (DN100...DN2500)
<b>Accuracy</b>	Volume flow (Q): ±0.5 % of measured value with process calibration

<b>Protection</b>	IP68
<b>Ex Approval</b>	ATEX / IECEx Zone 1 (optional); see Chap. "7 Ex Protection"
<b>Operation Temperature</b>	-20 °C ≤ Ta ≤ +50 °C Ex Version: -40 °C ≤ Ta ≤ 80 °C
<b>Storage Temperature</b>	-40 °C...+80 °C
<b>Cable length</b>	10/15/20/30/40/50/60/70/80/90/100 m
<b>Cable Type</b>	Twinax 2x AWG 20/7
<b>Outside Cable Diameter</b>	6.0 mm
<b>Sensor Types</b>	Pipe sensor incl. fastening element for installation using nozzle on pipe
<b>Medium contacting Materials</b>	Pipe sensor: stainless steel 1.4571/AISI 316 Ti, CFK (Carbon), NBR, HDPE
<b>Operation Pressure</b>	Pipe sensor: max. 16 bar (with fastening element) (others upon request)
<b>Temperature Measurement using Sound Velocity</b>	
<b>Measurement Range in the Medium</b>	0 °C...+60 °C
<b>Measurement Uncertainty</b>	±1 K

Tab. 14 Specifications Type TSP0

### 19.6 Flow Velocity Sensors Type NIC-CO

<b>Measurement Principle</b>	Ultrasonic transit time difference as contactless sensors
<b>Materials</b>	PEEK and stainless steel 1.4301/AISI 304
<b>Measurement Frequency</b>	1 MHz, 500 kHz
<b>Velocity Range</b>	±25 m/s Minimum flow velocity: 0.01 m/s
<b>Internal Pipe Diameter</b>	0.05...6.00 m (DN50...DN6000) NIC-CO01: DN50...DN2500 NIC-CO50: DN500...DN6000
<b>Protection</b>	IP68
<b>Ex Approval</b>	ATEX / IECEx Zone 1 (optional); see Chap. "7 Ex Protection"
<b>Operation Temperature</b>	-40 °C ≤ Ta ≤ +80 °C
<b>Storage Temperature</b>	-40 °C...+80 °C (non-condensing)
<b>Cable length</b>	7/10/20/30/40/50 m
<b>Cable Type</b>	Twinax 2x AWG 20/7
<b>Outside Cable Diameter</b>	6.0 mm
<b>Sensor Types</b>	Pair of sensors to clamp onto the pipe
<b>Accuracy</b>	Volume flow (Q): ±0.5 % of measured value with process calibration
<b>Temperature Measurement using Sound Velocity</b>	
<b>Measurement Range in the Medium</b>	0 °C...+80 °C
<b>Measurement Uncertainty</b>	±1 K

Tab. 15 Specifications Type NIC-CO

## Installation and Connection

### 20 Sensor Dimensions

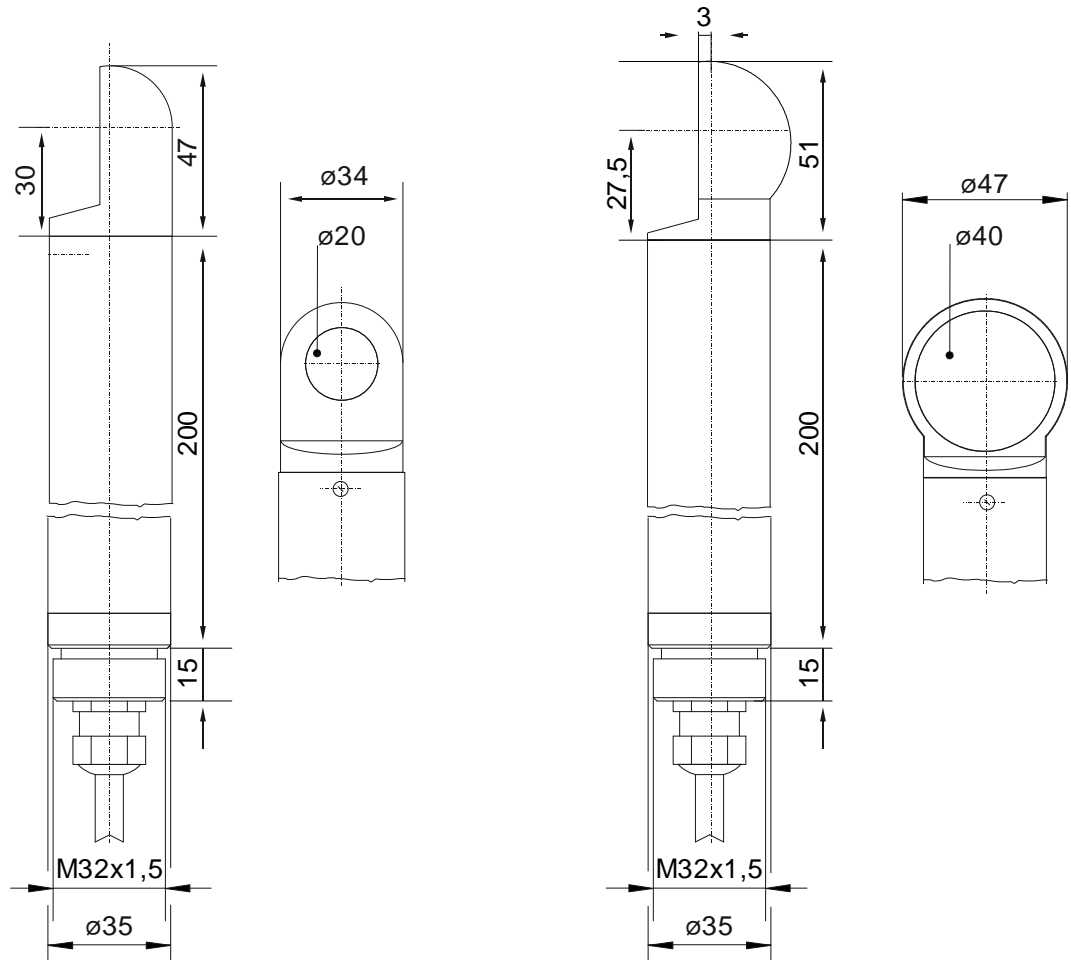

Fig. 20-1 Dimensioned drawing rod sensor Type NOS-V200/V300 mit  $\varnothing$  20/40 mm

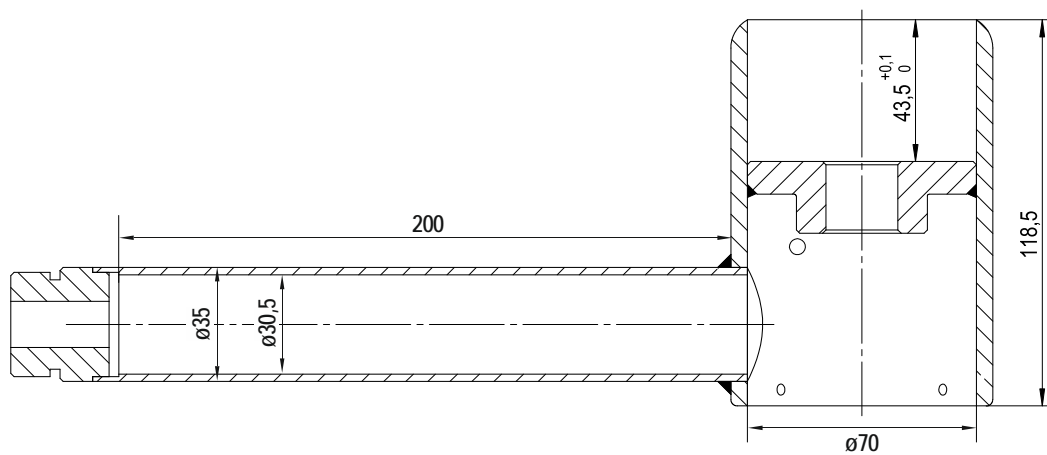

Fig. 20-2 Dimensioned drawing rod sensor Type NOS-V40

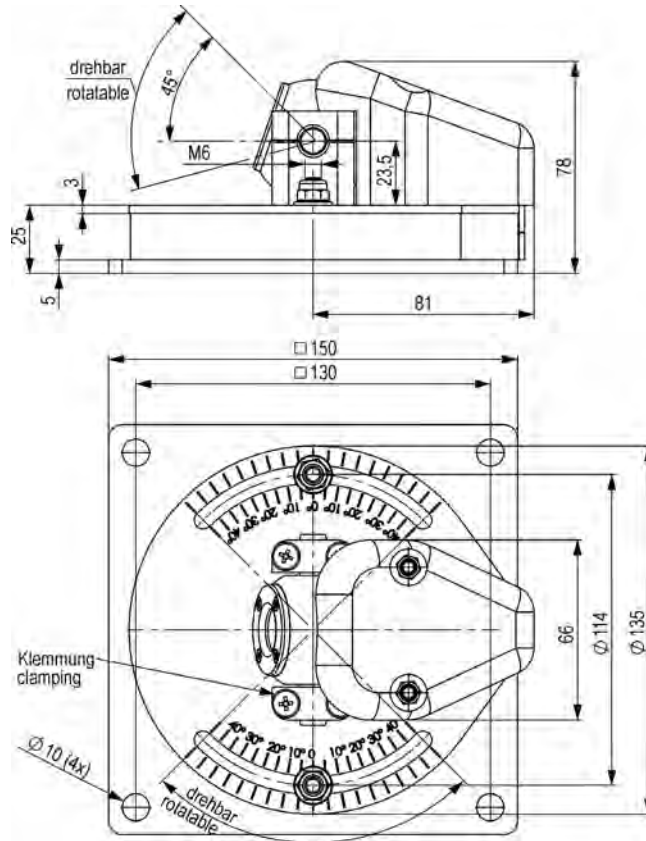

Fig. 20-3 Dimensioned drawing ball head sensor Type NOS-V20BS

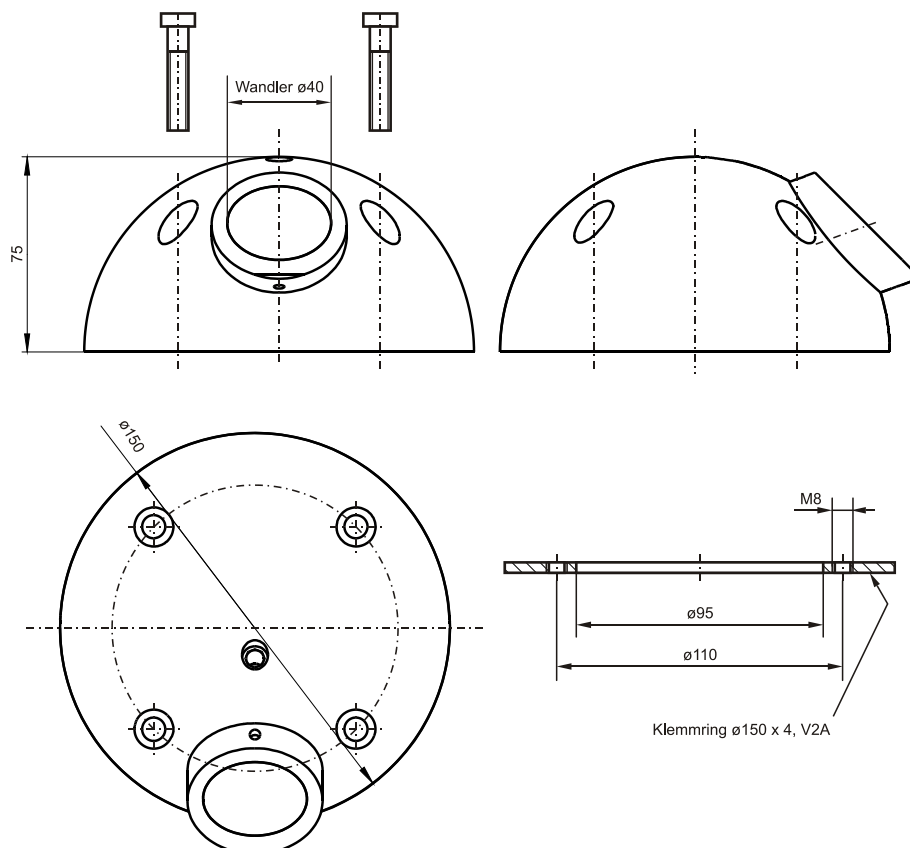

Fig. 20-4 Dimensioned drawing hemisphere sensor Type NOS-V30B ø 40 mm

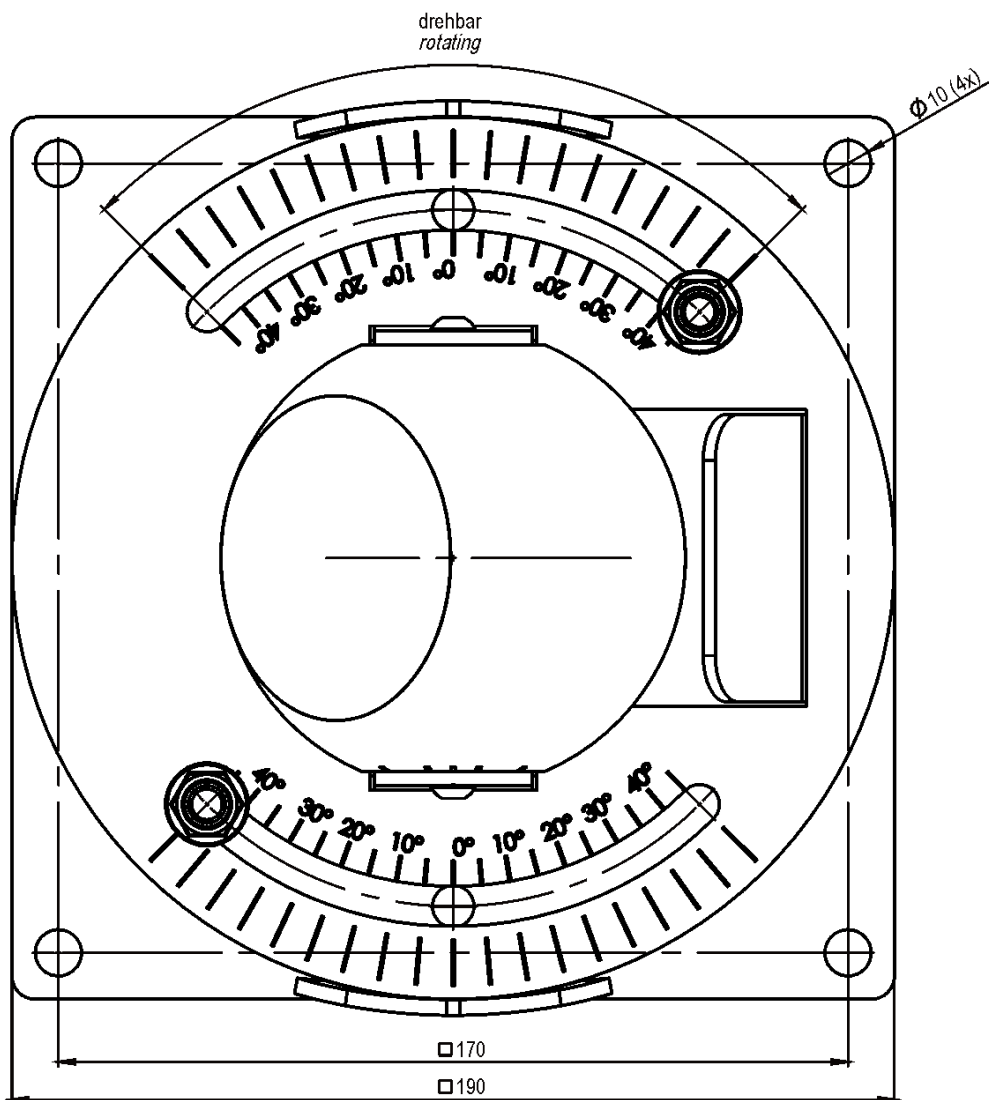
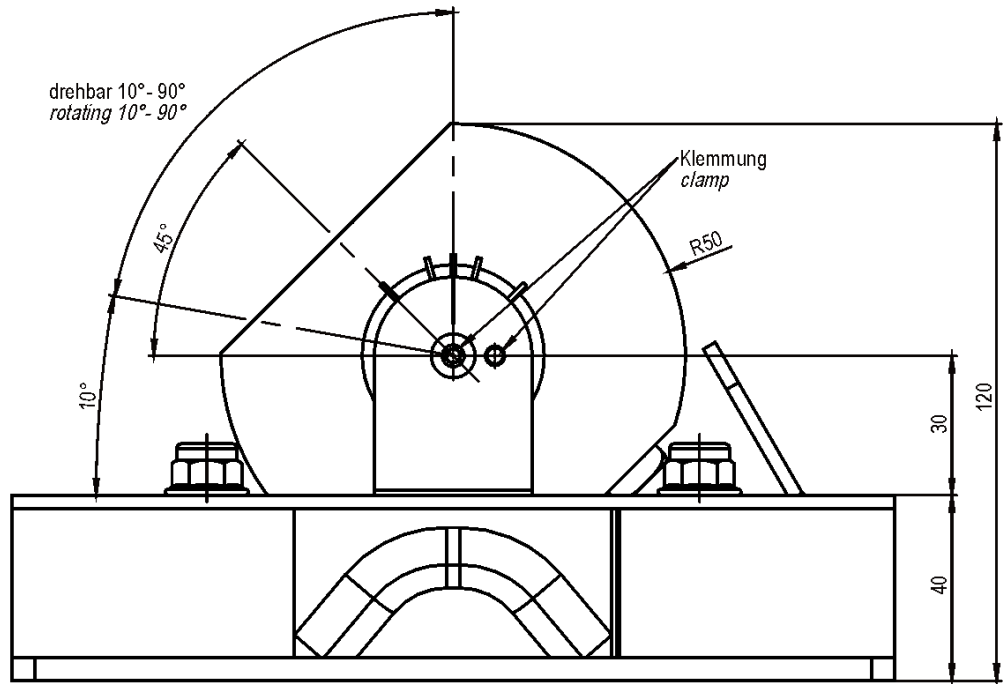

Fig. 20-5 Dimensioned drawing ball sensor Type NOS0H0V200

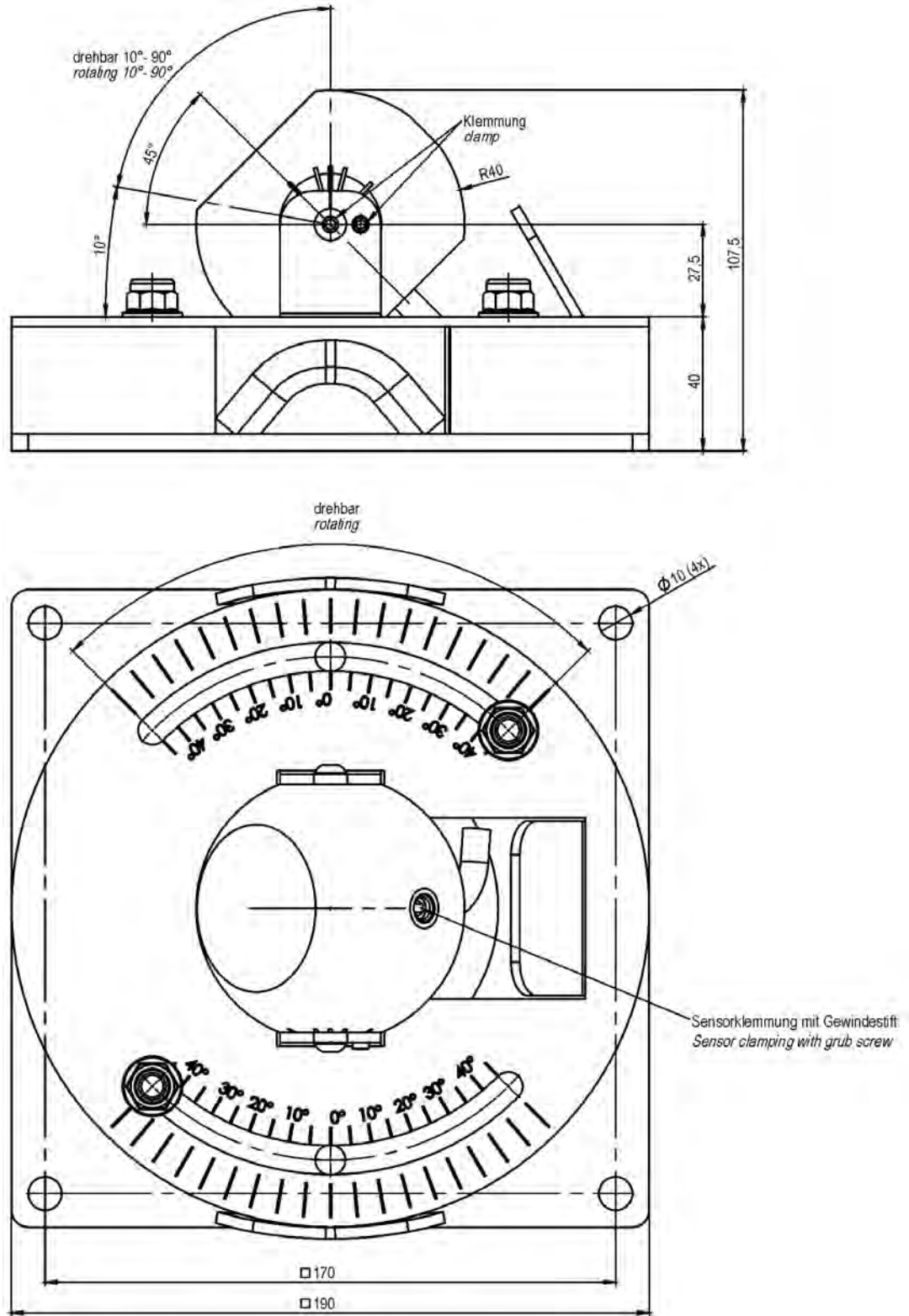

Fig. 20-6 Dimensioned drawing ball sensor Type NOS0H0V500

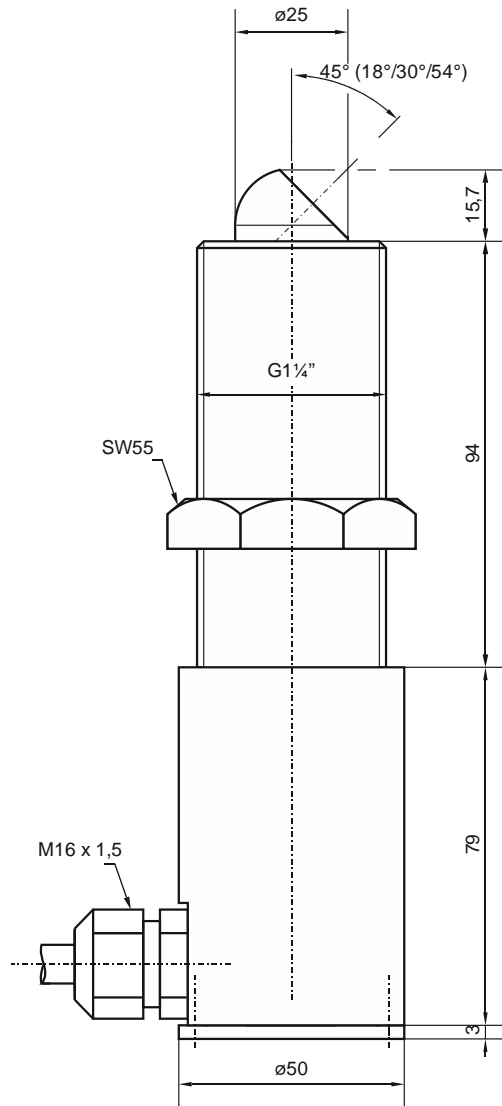
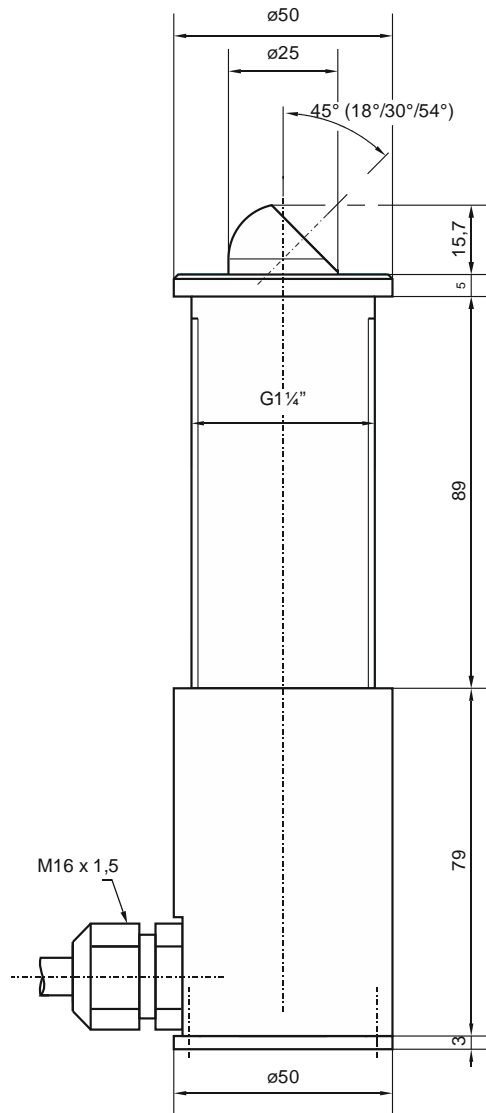
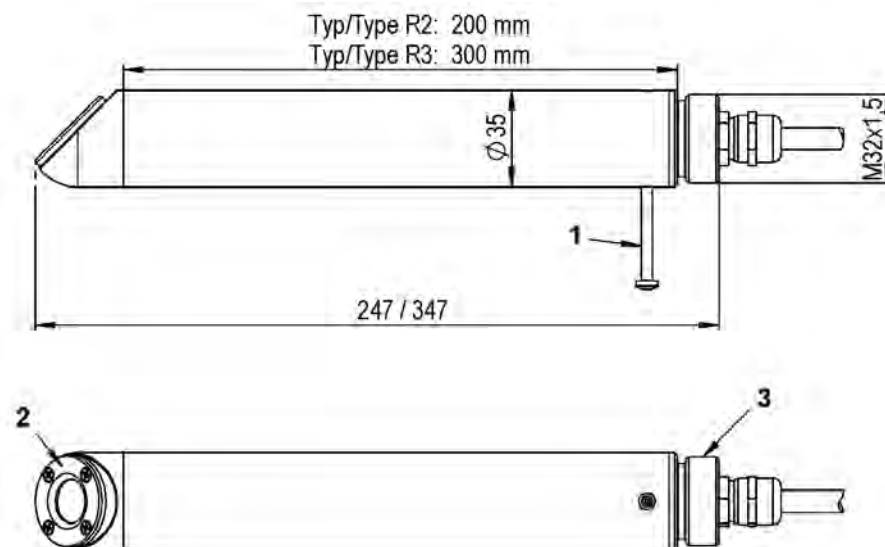

Fig. 20-7 Dimensioned drawing screw-in sensor Type NOS-V2E



**Fig. 20-8 Dimensioned drawing plug-in sensor Type NOS-V2S**



- 1 Alignment screw
- 2 Sealing washer

3 To screw on extension tubes

**Fig. 20-9 Dimensioned drawing pipe sensor Type NIS-V200RT**

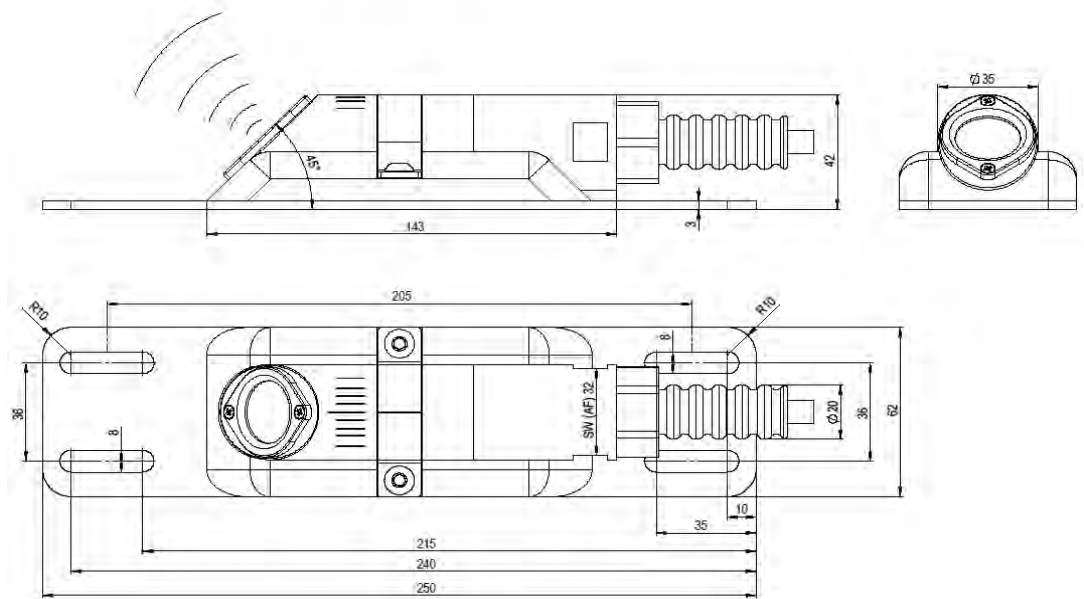

**Fig. 20-10 Dimensioned drawing wedge sensor Type NIS-V280KS**

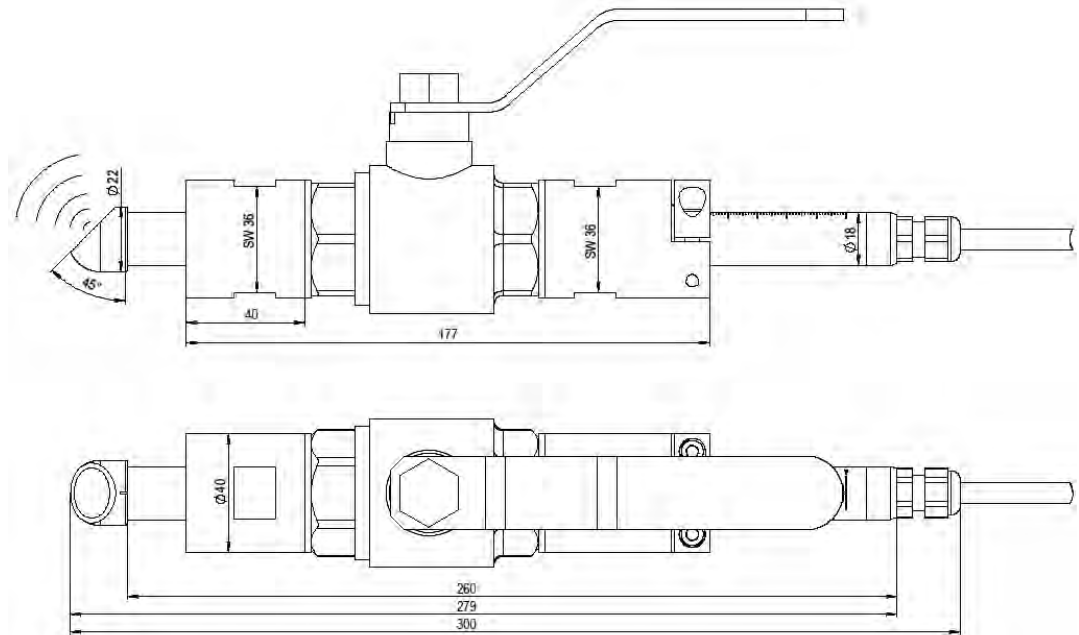

**Fig. 20-11 Dimensioned drawing pipe sensor Type NIS0V200RL**

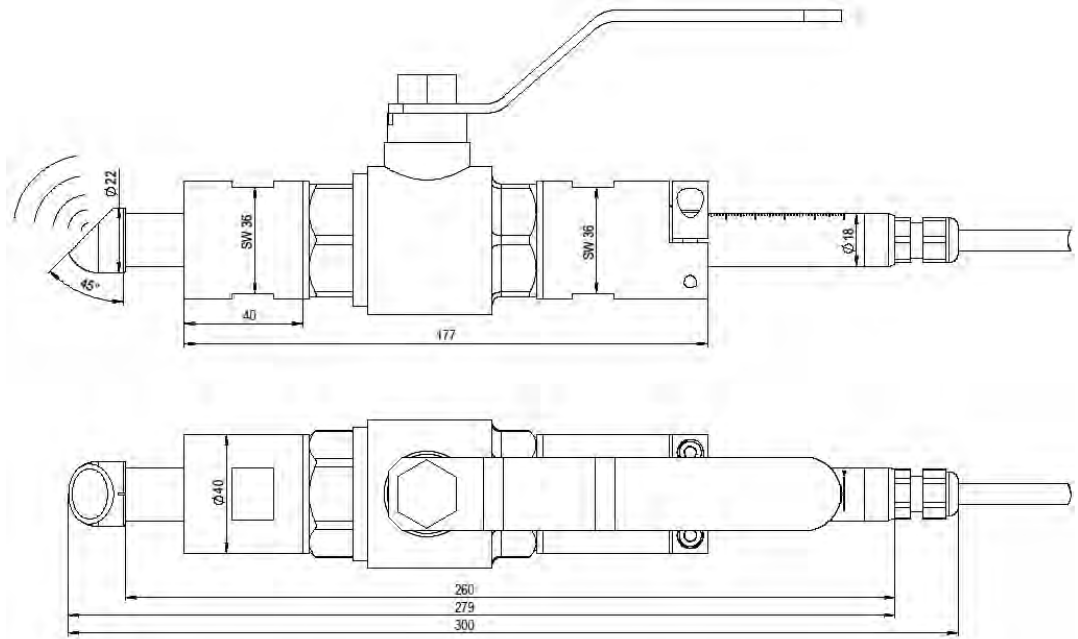

Fig. 20-12 Dimensioned drawing pipe sensor Type TSP0V200RL

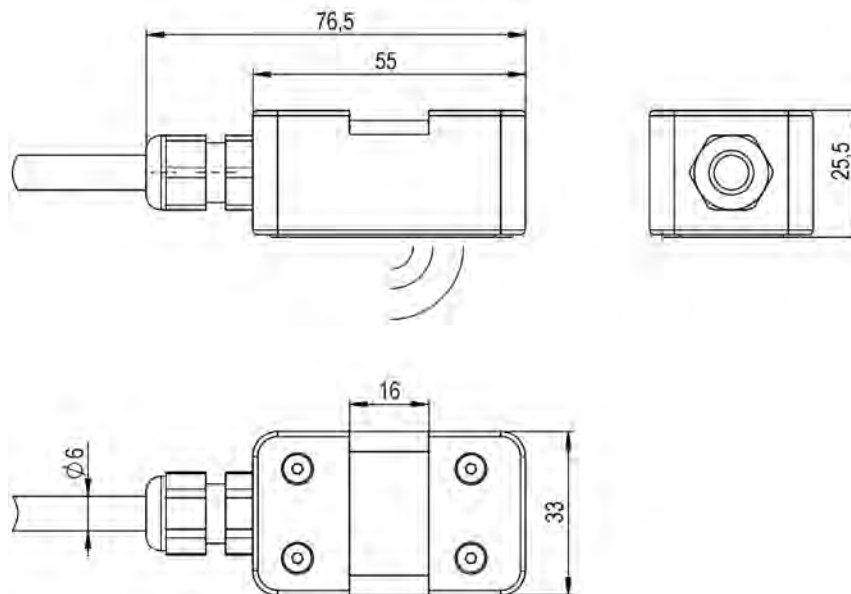

Fig. 20-13 Dimensioned drawing clamp-on sensor Type NIC-CO01

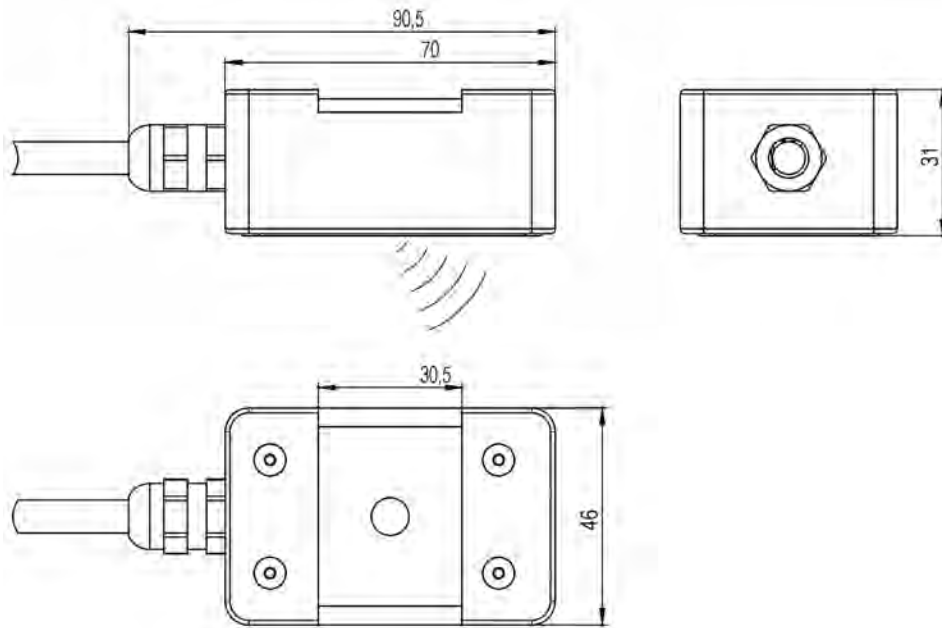
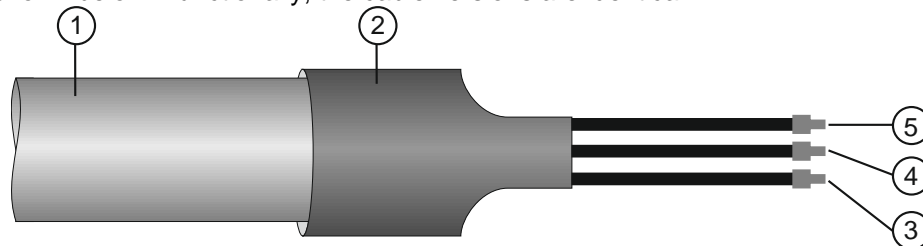

Fig. 20-14 Dimensioned drawing clamp-on sensor Type NIC-CO50

## 21 Cable Layouts

Depending on our suppliers, the cables can be manufactured in one of the two versions shown below. Functionally, the cable versions are identical.



Pos.	Version 1	Version 2
1	Cable sheath	Cable sheath
2	Heat shrink tubing	Heat shrink tubing
3	Silver-coloured wire with <b>black</b> cable sheath; shield (no ground)	Silver-coloured wire with <b>black</b> cable sheath; shield (no ground)
4	<b>Copper-coloured</b> wire with transparent cable sheath; CH +	Silver-coloured wire with <b>white</b> cable sheath; CH +
5	<b>Silver-coloured</b> wire with transparent cable sheath; CH -	<b>Silver-coloured</b> wire with transparent cable sheath; CH -

Fig. 21-1 Cable tail layout sensors

## 22 Sensor cable

### 22.1 Cable Extension

The sensors are equipped with a permanently connected cable Type "Twinax 2x AWG 20" in different lengths.

This cable must not be shortened.

The cable extension can be ordered from NIVUS ex works at a charge. In addition to the technically optimal connection, the sensor here is also calibrated to ensure its performance.

The sensors of the individual measurement paths are connected to the transmitter directly (two or four sensor pairs) or via an extension module. Distances of up to 250 / 300 m can be achieved).

### CAUTION



#### **Cable extension: Observe max. cable length and carry out calibration**

When extending the sensor cables, please note that the extension is only permitted with the special cable supplied by NIVUS GmbH as well as the corresponding connection technology (terminal boxes, casting sleeves, etc.).

The **max. total length** of the sensor cable of **100 m** must not be exceeded.

A subsequent **calibration** is mandatory.

#### **No joint cable extensions!**

Joint extensions of different applications or joint extensions of separate level and flow velocity measurements in a common signal cable are **not permitted**.

#### **Cable lengths within a path must be identical**

The sensor cables of each path must have exactly the same length, otherwise measurement errors or failures may occur.

## 23 Resistance List

### CAUTION



#### **Damage due to aggressive media**

In principle, there is a risk of pitting on the stainless steel mounting plate or on the pipe sensor jacket with media containing chloride.

Hydrogen sulphide (H<sub>2</sub>S - danger of diffusion through cable sheath) and various organic solvents can corrode the sensor material.

**Only** install sensors or cables in suitable media, otherwise the sensor/cable material may be damaged/destroyed. It is essential to observe the following resistance list.

The parts of the sensors that come into contact with the medium consist as standard of:

- 1.4571/AISI 316 Ti (pipe sensor jacket)
- Carbon CFK (sensor surface)
- PEEK (sensor crystal cover)
- Polyurethane (PUR) (cable sheath)
- 1.4305/AISI 303 (screw connection)
- Viton (PA/PR) (gasket)

The sensor systems are resistant to all common types of water, wastewater and rainwater as well as combined water from municipalities and local authorities. Resistance is also not a problem in many industrial plants (e.g. Hüls, BASF, etc.). Nevertheless, sensor systems are not resistant to all substances and substance mixtures.

In the case of substance mixtures (simultaneous presence of several substances), catalytic effects may occur under certain circumstances, which do not appear in the presence of the individual substance. These catalytic effects cannot be completely tested due to the infinite possibilities of variations.

If in doubt, contact your local NIVUS representative and request a free material sample for long-term testing.

MEDIUM	FORMULA	CONCENTRATION	HDPE	PPO GF30	PUR	PEEK	FEP	V4A	Hastelloy C 276	Viton (PA/PR)	PA GF30	PVDF	EP-T
Acetaldehyde	C <sub>2</sub> H <sub>4</sub> O	40 %	3/3	4	4	1	(1)	(1)	0	4/4	2/4	4/4	3/4
Acetic acid	C <sub>2</sub> H <sub>4</sub> O <sub>2</sub>	10 %	1/1	2	3	1	1/1	1/1	1	(3)	4/4	1/1	1/1
Acetone	C <sub>3</sub> H <sub>6</sub> O	40 %	1/1	4	4	1	(1)	1/1	1	4/4	1/0	3/4	1/3
Allyl alcohol	C <sub>3</sub> H <sub>6</sub> O	96 %	1/3	2	0	1	1/1	1/1	0	4/4	3/0	(2)	2/2
Aluminium chloride	AlCl <sub>3</sub>	10 %	1/1	2	0	1	1/1	3/4	1	1/0	1/0	1/1	1/1
Ammonium chloride	(NH <sub>4</sub> )Cl	watery	1/1	1	0	1	1/1	1/1	1	1/1	3/4	1/1	0/0
Ammonium hydroxide	NH <sub>3</sub> + H <sub>2</sub> O	5 %	1/1	2	4	1	1/1	1/1	1	(2)	(2)	(2)	1/1
Aniline	C <sub>6</sub> H <sub>7</sub> N	100 %	1/2	3	4	1	1/1	1/0	1	2/4	3/4	1/4	2/3
Benzene	C <sub>6</sub> H <sub>6</sub>	100 %	3/4	3/4	2	1	1/1	1/1	1	3/3	2/0	1/3	3/4
Benzyl alcohol	C <sub>7</sub> H <sub>8</sub> O	100 %	3/4	3	2	1	1/1	1/1	1	1/0	4/4	1/1	4/4
Boric acid	H <sub>3</sub> BO <sub>3</sub>	10 %	1/1	1	1	1	1/1	1/1	1	1/1	1/0	1/1	1/1
Bromic acid	HBrO <sub>3</sub>	concentr.	0/0	0	3	1	0/0	(4)	0	(2)	(4)	(1)	3/0
Butanol	C <sub>4</sub> H <sub>10</sub> O	techn. pure	1/1	2	3	1	1/1	(1)	1	3/4	1/0	(2)	1/2
Calcium chloride	CaCl <sub>2</sub>	spirituous	1/0	1	1	1	1/1	1/2L	1	1/1	4/4	1/1	1/1
Carbon disulphide	CS <sub>2</sub>	100 %	4/4	2	0	1	1/1	1/1	1	1/0	3/0	1/0	4/4
Carbon tetrachloride	CCl <sub>4</sub>	100 %	4/4	3	4	1	1/1	1/1L	1	1/1	4/4	1/1	4/4
Caustic soda	NaHO	50 %	1/1	1	3	1	1/1	1/3	1	3/3	1/0	1/1	1/1
Chlorine	Cl <sub>2</sub>		4/4	3	3	1	1/1	1/0	0	1/1	4/4	1/0	4/4
Chlorine water	Cl <sub>2</sub> x H <sub>2</sub> O		3/0	2	0	1	(1)	2/0L	1	1/0	4/4	1/1	3/4
Chlorobenzene	C <sub>6</sub> H <sub>5</sub> Cl	100 %	3/4	3	4	1	1/1	1/1	1	3/4	4/4	1/1	3/4
Chloroform	CHCl <sub>3</sub>	100 %	3/4	4	4	1	1/1	1/1	1	4/4	3/4	1/1	3/4
Chloromethane	CH <sub>3</sub> Cl	techn. pure	3/0	4	4	1	1/0	1/1L	0	4/4	(3)	1/0	4/4
Chromic acid	CrO <sub>3</sub>	10 %	1/1	1	0	1	1/1	1/2	1	1/1	4/4	1/1	1/1
Citric acid	C <sub>6</sub> H <sub>8</sub> O <sub>7</sub>	10 %	1/1	1	1	1	1/1	1/1	1	1/1	1/1	1/1	1/1
Diesel	—	100 %	1/3	2	0	1	(1)	(1)	0	1/1	1/1	1/1	1/3
Ethanedioic acid	C <sub>2</sub> H <sub>2</sub> O <sub>3</sub> x 2H <sub>2</sub> O	watery	1/1	2	0	1	1/1	1/3	2	1/1	4/4	1/1	1/1
Ethanol	C <sub>2</sub> H <sub>5</sub> O	96 %	1/0	1	1	1	1/1	1/1	1	3/0	1/0	1/1	1/1
Ethyl acetate	C <sub>4</sub> H <sub>8</sub> O <sub>2</sub>	100 %	1/3	3	3	1	1/1	(1)	0	4/4	1/0	1/1	1/3
Ethyl alcohol	C <sub>2</sub> H <sub>5</sub> O	100 %	1/0	1	1	1	1/1	1/1	0	3/0	1/0	1/1	0/0
Ethylen chloride	C <sub>2</sub> H <sub>4</sub> Cl <sub>2</sub>		3/3	4	3	1	1/1	1/1L	1	3/0	3/0	1/1	3/4
Ferric chloride	FeCl <sub>3</sub>	saturated	1/1	2	3	2	1/1	4/4	0	1/1	3/0	1/1	1/1
Formaldehyd dilution	CH <sub>2</sub> O	10 %	1/1	1	2	1	1/1	1/1	1	3/0	3/3	1/1	1/1
Glycerin	C <sub>3</sub> H <sub>8</sub> O <sub>3</sub>	90%	1/1	1	2	1	1/1	1/1	1	1/1	1/0	1/1	1/1
Heptane	C <sub>7</sub> H <sub>16</sub>	90%	2/3	1	1	1	1/1	1/1	1	1/1	1/0	1/1	0/0
Hexane	C <sub>6</sub> H <sub>14</sub>	100 %	2/3	1	2	1	1/1	1/1	1	1/1	4/4	1/1	2/3
Hydrochloric acid	HCl	1-5 %	1/1	1	3	1	1/1	4/4	1	1/1	4/4	1/1	1/1
Hydrofluoric acid	HF	50 %	1/1	2	3	1	1/1	4/4	2	1/3	4/4	1/1	1/1
Hydroxypropionic acid	C <sub>3</sub> H <sub>5</sub> O <sub>3</sub>	3 %	1/1	1	0	1	1/1	1/1	1	1/1	(3)	1/1	1/2
Isopropanol	C <sub>3</sub> H <sub>8</sub> O	techn. pure	1/1	1	2	1	1/1	(1)	1	1/1	1/0	0/0	1/1
Magnesium chloride	MgCl <sub>2</sub>	watery	1/1	1	2	1	1/1	1/0L	1	1/1	1/0	1/1	1/1
Mercuric chloride	HgCl <sub>2</sub>	watery	1/1	1	0	1	1/1	(4)	1	1/1	4/4	1/1	1/1
Methanol	CH <sub>4</sub> O		1/1	1	2	1	1/1	1/1	1	3/4	2/0	1/1	1/1
Methyl acetate	C <sub>3</sub> H <sub>6</sub> O <sub>2</sub>	techn. pure	1/0	3	0	1	1/0	1/1	1	4/4	1/0	1/1	1/3
Nitric acid	HNO <sub>3</sub>	1-10 %	1/1	1	3	1	1/1	1/1	1	1/1	4/4	1/1	1/1
Nitrobenzene	C <sub>6</sub> H <sub>5</sub> NO <sub>2</sub>		3/4	3	4	1	1/1	1/1	0	4/4	4/4	1/1	2/4
Oleic acid	C <sub>18</sub> H <sub>34</sub> O <sub>2</sub>	techn. pure	1/3	1	1	1	(1)	1/1	0	2/2	1/0	1/1	1/3
Ozone	O <sub>3</sub>		3/4	2	2	1	1/1	0/0	0	1/0	4/4	(1)	3/4
Petrol, unleaded	C <sub>8</sub> H <sub>12</sub> - C <sub>12</sub> H <sub>26</sub>		2/3	3	2	1	1/1	1/1	1	(1-3)	1/0	1/1	3/4
Petroleum	—		1/1	1	1	1	1/1	1/1	1	1/1	(1)	1/0	1/3
Petroleum	—	techn. pure	1/3	3	1	1	(1)	1/1	0	1/0	1/0	0/0	1/3
Phenol	C <sub>6</sub> H <sub>6</sub> O	100 %	2/3	3	2	1	1/1	1/1	1	2/3	4/4	1/1	1/2
Phenylmethane (Toluol)	C <sub>7</sub> H <sub>8</sub>	100 %	3/4	3	3	1	1/1	1/1	0	3/3	1/0	1/1	3/4
Phosphoric acid	H <sub>3</sub> PO <sub>4</sub>	85 %	1/1	1	0	1	1/1	1/3	1	1/1	4/4	1/1	1/2
Potassium hydroxide	KHO	10 %	1/1	1	3	1	1/1	1/1	1	4/4	1/0	1/1	1/1
Potassium nitrate	KNO <sub>3</sub>	watery	1/1	1	0	1	1/1	1/1	1	1/1	1/0	1/1	1/1
Sodium bisulphite	NaHSO <sub>3</sub>	watery	1/1	1	0	1	(1)	1/1	1	1/0	1/0	1/1	1/1
Sodium carbonate	Na <sub>2</sub> CO <sub>3</sub>	watery	1/1	1	3	1	1/1	1/1	1	1/1	1/0	1/1	1/1
Sodium chloride	NaCl	watery	1/1	1	2	1	1/1	1/2	1	1/1	1/1	1/1	1/1
Sodium sulphate	Na <sub>2</sub> SO <sub>4</sub>	watery	1/1	1	0	1	1/1	1/1	1	1/1	1/0	1/1	1/1
Sulphuric acid	H <sub>2</sub> SO <sub>4</sub>	40 %	1/1	1	3	1	1/1	2/3	1	1/1	4/4	1/1	1/1
Trichloroethylene	C <sub>2</sub> HCl <sub>3</sub>	100 %	3/4	4	4	1	1/1	1/1L	1	1/3	3/0	1/0	4/4
Vegetable oils	—		0/0	1	1	1	(1)	1/1	0	1/0	0/0	1/1	1/3

**Tab. 16 Resistance List**

**Resistance List Legend**

Two values are given per medium (e.g. 1/3).

left figure = value at +20 °C

right figure = value at +50 °C

- 0 no information available/no statement possible
- 1 very good resistance/suitability
- 2 good resistance/suitability

3	limited resistance
4	no resistance
K	no general information possible
L	risk of pitting or stress corrosion cracking
()	estimated value

**Material Name**

HDPE	high density Polyethylene
PPO GF30	Polyphenyloxylyene with 30 % glass fibre content
PUR/PU	Polyurethane
PEEK	Polyetheretherketone
FEP	Tetrafluorethylene-Perfluorpropylene
V4A/Stainless steel	1.4571/AISI 316Ti or 1.4301/AISI 304
Hastelloy C276	Highly corrosion-resistant Nickel-Molybdenum alloy (brand name)
Viton (PA/PR)	Fluoroelastomer (brand name)
PA GF30	Polyamide with 30 % glass fibre content
PVDF	Polyvinylidene Fluoride

## Maintenance and Cleaning

---

### WARNING



#### **Check danger due to explosive gases**

Before starting assembly, installation and maintenance work, be sure to check that all regulations on safety at work have been observed and that there is no possible risk of explosive gases. Use a gas warner for the check.

When working in the sewer system, make sure that no electrostatic charge can occur:

- Avoid unnecessary movements to reduce the building-up of static charges.
- Discharge any static electricity present on your body before you start installing the sensor.

Disregarding may result in personal injury or damage to the system.

---

### WARNING



#### **Germ Contamination**

Due to the frequent use of the sensors in the waste water sector, parts can be contaminated with dangerous germs. Therefore, appropriate precautions must be taken when coming into contact with cables and sensors.

Wear protective clothing.

---

## 24 Maintenance

### 24.1 Maintenance Interval

The NIVUS sensors are virtually calibration-, maintenance- and wear-free by design.

Nevertheless, NIVUS recommend an **annual check** of the entire measuring system by the NIVUS customer service.

Depending on the area of application of the measuring system, the maintenance interval may vary. The scope of maintenance and its intervals depend on the following factors:

- Measurement principle of the sensors
- Material wear
- Measurement medium and channel hydraulics
- General regulations for the operator of the measurement system
- Environmental conditions

In addition to the annual maintenance, NIVUS recommend a complete maintenance of the measuring system by the NIVUS customer service after **ten years at the latest**.

Generally, the verification of instruments and sensors is a basic measure in order to improve operational reliability and to increase the lifetime.

### 24.2 Customer Service Information

For the recommended annual inspection of the entire measuring system or complete maintenance after ten years at the latest, contact our customer service:

#### **NIVUS GmbH - Customer Centre**

Phone +49 7262 9191-922

[customercenter@nivus.com](mailto:customercenter@nivus.com)

## 25 Cleaning

In media with a tendency to be deposited by algae or flotsam and soiling due to moss on the sensor, it may be necessary to clean the flow velocity sensor at regular intervals. Use a brush with plastic bristles, a street broom or similar for this purpose.

### CAUTION



#### **Damage caused by hard Objects**

*Never use hard objects such as wire brushes, rods, scrapers or similar to clean the sensor. The use of water jet cleaning is only permissible up to a permissible flushing pressure of max. 4 bar (see chapter "19 Specifications") (e.g. hosing down with a water hose).*

*The use of high-pressure cleaners may damage the sensor and lead to measurement failure and is therefore strictly prohibited.*

---

## 26 Dismantling/Disposal

Dispose of the sensors in accordance with the applicable local environmental regulations for electrical products.

➡ Procedure:

1. Disconnect the measurement system from the mains.
2. Use a suitable tool to disconnect the connected cables from the transmitter.
3. Remove the sensors.



#### **EU WEEE Directive**

*This symbol indicates that the requirements of Directive 2012/19/EU on waste electrical and electronic equipment must be observed when disposing of the device. Die NIVUS GmbH support and promote the recycling or environmentally sound, separate collection/disposal of waste electrical and electronic equipment to protect the environments and human health. Observe the local laws and regulations on disposal.*

*NIVUS GmbH is registered with the EAR, therefore public collection and return points in Germany can be used for disposal.*

---

## 27 Installation of Spare Parts and Wearing Parts

We expressly draw your attention to the fact that spare parts and accessories which have not been supplied by us have also not been tested and approved by us. The installation and/or use of such products may therefore negatively alter or invalidate the design properties of your measurement system.

NIVUS are not liable for damage caused by the use of non-original parts and non-original accessories.

## 28 Accessories (Option)

Article Number	Description
<b>Rod sensors</b>	
<i>NOZ0 0HAL0</i>	Holder bracket for fastening of rod sensors on a vertical wall
<i>NOZ0 0HAL90</i>	90° holding device for attaching a rod sensor to a horizontal surface
<i>NOZ0 0STR BL</i>	Flow-optimised protective sheet for rod sensors
<i>NOZ0 ROHR VE1</i>	Extension for the mounting tube for rod sensors
<b>Screw-in sensors</b>	
<i>ZUB0 STU14 V4A</i>	Weld-on socket, whole socket, straight type 1 ¼", stainless steel
<i>ZUB0 STU14 ST</i>	Weld-on socket, whole socket, straight type 1 ¼", ST37
<b>Hemisphere sensors</b>	
<i>NOS0 0HAL 1VK</i>	Holder bracket for fastening of hemisphere sensors on an abutment, for type NOS-V20BS
<i>NOZ0 0HAL HK</i>	Holder bracket for fastening of hemisphere sensors on an abutment, for Type NOS-V30B
<b>Pipe sensors</b>	
<i>ZUB0 HAHN R15</i>	Stop ball valve 1 ½" to remove pipe sensors from pipes without pressure
<i>ZUB0 ABS xxx</i>	Tapping saddle for installation of 1½" pipe sensors in pipelines
<i>ZUB0 ABP xxx</i>	Tapping plate for installation of pipe sensors
<b>Clamp-On sensors</b>	
<i>ZUB-CO RA xxxxxxxx</i>	Mounting system clamp-on sensor holder and tensioning belts
<i>ZUB0 KOF 100</i>	Coupling grease tube 75 g

Tab. 17 Accessories



More accessories can be found in the current NIVUS price list or NIVUS parts list.

## Index

<b>A</b>		
Accessories.....	51	
Approvals.....	53	
Article Number.....	24	
<b>C</b>		
Cable.....	45	
Layout.....	45	
Certificates.....	53	
Channel Width - Sensor Selection.....	32	
Clamp-On Sensors		
Wall Thickness.....	33	
Cleaning.....	49, 50	
Connection.....	37	
Copyright.....	3	
Customer Centre.....	49	
<b>D</b>		
Device ID.....	22	
Disclaimer.....	10	
<b>E</b>		
Electrostatic Discharge.....	12	
<b>G</b>		
Germs.....	9, 49	
<b>I</b>		
Inspection upon Receipt.....	14	
Installation.....	37	
<b>M</b>		
Maintenance.....	49	
Maintenance Interval.....	49	
<b>N</b>		
Nameplate.....	22	
Names.....	3	
National Language.....	3	
<b>O</b>		
Operator's Duties.....	12	
<b>P</b>		
Pipe Inside Diameter - Sensor Selection.....	32	
Protective Clothing.....	9	
<b>Q</b>		
Qualified Personnel.....	7	
<b>R</b>		
Resistance.....	46	
Return.....	14	
<b>S</b>		
Safety at Work.....	9	
Safety Devices.....	9	
Scope of Delivery.....	14	
Sensor Versions.....	24	
Spare Parts.....	50	
Specifications.....	33	
Storage.....	14	
<b>T</b>		
Tip		
Channel Width - Sensor Selection.....	32	
Pipe Inside Diameter - Sensor Selection.....	32	
Translation.....	3	
Transport.....	14	
<b>W</b>		
Wall Thickness		
Clamp-On Sensors.....	33	
Wearing Parts.....	50	

## Approvals and Certificates

DE / EN / FR									
	NIVUS GmbH Im Taele 2 75031 Eppingen  Telefon: +49 07262 9191-0 Telefax: +49 07262 9191-999 E-Mail: info@nivus.com Internet: www.nivus.de								
	<p><b>EU Konformitätserklärung</b>  <i>EU Declaration of Conformity</i>  <i>Déclaration de conformité UE</i></p> <p>Für das folgend bezeichnete Erzeugnis:  <i>For the following product:</i>  <i>Le produit désigné ci-dessous:</i></p>								
	<table border="0"> <tr> <td><b>Bezeichnung:</b></td> <td><b>Ultraschall - Laufzeitdifferenzsensoren</b></td> </tr> <tr> <td><i>Description:</i></td> <td><i>Ultrasonic transit time sensors</i></td> </tr> <tr> <td><i>Désignation:</i></td> <td><i>Capteurs par différence de temps de transit via ultrasons</i></td> </tr> <tr> <td><b>Typ / Type:</b></td> <td><b>NOS-... / NOS0...</b></td> </tr> </table>	<b>Bezeichnung:</b>	<b>Ultraschall - Laufzeitdifferenzsensoren</b>	<i>Description:</i>	<i>Ultrasonic transit time sensors</i>	<i>Désignation:</i>	<i>Capteurs par différence de temps de transit via ultrasons</i>	<b>Typ / Type:</b>	<b>NOS-... / NOS0...</b>
<b>Bezeichnung:</b>	<b>Ultraschall - Laufzeitdifferenzsensoren</b>								
<i>Description:</i>	<i>Ultrasonic transit time sensors</i>								
<i>Désignation:</i>	<i>Capteurs par différence de temps de transit via ultrasons</i>								
<b>Typ / Type:</b>	<b>NOS-... / NOS0...</b>								
	<p>erklären wir in alleiniger Verantwortung, dass die auf dem Unionsmarkt ab dem Zeitpunkt der Unterzeichnung bereitgestellten Geräte die folgenden einschlägigen Harmonisierungsvorschriften der Union erfüllen:  <i>we declare under our sole responsibility that the equipment made available on the Union market as of the date of signature of this document meets the standards of the following applicable Union harmonisation legislation:</i>  <i>nous déclarons, sous notre seule responsabilité, à la date de la présente signature, la conformité du produit pour le marché de l'Union, aux directives d'harmonisation de la législation au sein de l'Union:</i></p> <p style="text-align: center;">• 2014/30/EU                      • 2011/65/EU</p> <p>Bei der Bewertung wurden folgende einschlägige harmonisierte Normen zugrunde gelegt bzw. wird die Konformität erklärt in Bezug auf die nachfolgend genannten anderen technischen Spezifikationen:  <i>The evaluation assessed the following applicable harmonised standards or the conformity is declared in relation to other technical specifications listed below:</i>  <i>L'évaluation est effectuée à partir des normes harmonisées applicable ou la conformité est déclarée en relation aux autres spécifications techniques désignées ci-dessous:</i></p> <p style="text-align: center;">• EN 61326-1:2013</p> <p>Diese Erklärung wird verantwortlich für den Hersteller:  <i>This declaration is submitted on behalf of the manufacturer:</i>  <i>Le fabricant assume la responsabilité de cette déclaration:</i></p> <p style="text-align: center;"><b>NIVUS GmbH</b>  <b>Im Taele 2</b>  <b>75031 Eppingen</b>  <b>Allemagne</b></p> <p>abgegeben durch / <i>represented by / faite par:</i>  <b>Udo Steppe</b> (Geschäftsführer / <i>Managing Director / Directeur général</i>)</p> <p>Eppingen, den 11.08.2021</p> <p>Gez. <i>Udo Steppe</i></p>								

DE / EN / FR

## EU Konformitätserklärung

*EU Declaration of Conformity*

*Déclaration de conformité UE*

Für das folgend bezeichnete Erzeugnis:

*For the following product:*

*Le produit désigné ci-dessous:*



NIVUS GmbH  
Im Täle 2  
75031 Eppingen

Telefon: +49 07262 9191-0  
Telefax: +49 07262 9191-999  
E-Mail: info@nivus.com  
Internet: www.nivus.de

<b>Bezeichnung:</b>	<b>Ultraschall - Laufzeitsensoren</b>
<i>Description:</i>	<i>Ultrasonic transit time sensors</i>
<i>Désignation:</i>	<i>Capteurs ultrasoniques temps de transit</i>
<b>Typ / Type:</b>	<b>NIS-... / NIS0V2... / TSP0V2...</b>

erklären wir in alleiniger Verantwortung, dass die auf dem Unionsmarkt ab dem Zeitpunkt der Unterzeichnung bereitgestellten Geräte die folgenden einschlägigen Harmonisierungsvorschriften der Union erfüllen:

*we declare under our sole responsibility that the equipment made available on the Union market as of the date of signature of this document meets the standards of the following applicable Union harmonisation legislation:*

*nous déclarons, sous notre seule responsabilité, à la date de la présente signature, la conformité du produit pour le marché de l'Union, aux directives d'harmonisation de la législation au sein de l'Union:*

- 2014/30/EU
- 2011/65/EU

Bei der Bewertung wurden folgende einschlägige harmonisierte Normen zugrunde gelegt bzw. wird die Konformität erklärt in Bezug die nachfolgend genannten anderen technischen Spezifikationen:

*The evaluation assessed the following applicable harmonised standards or the conformity is declared in relation to other technical specifications listed below:*

*L'évaluation est effectuée à partir des normes harmonisées applicable ou la conformité est déclarée en relation aux autres spécifications techniques désignées ci-dessous:*

- EN 61326-1:2013

Diese Erklärung wird verantwortlich für den Hersteller:

*This declaration is submitted on behalf of the manufacturer:*

*Le fabricant assume la responsabilité de cette déclaration:*

**NIVUS GmbH**  
**Im Täle 2**  
**75031 Eppingen**  
**Allemagne**

abgegeben durch / *represented by / faite par:*

**Marcus Fischer** (Geschäftsführer / *Managing Director / Directeur général*)

Eppingen, den 26.06.2019

Gez. *Marcus Fischer*

DE/EN/FR



## EU Konformitätserklärung

*EU Declaration of Conformity*

*Déclaration de conformité UE*

NIVUS GmbH  
Im Taele 2  
75031 Eppingen

Telefon: +49 07262 9191-0  
Telefax: +49 07262 9191-999  
E-Mail: info@nivus.com  
Internet: www.nivus.de

Für das folgend bezeichnete Erzeugnis:

*For the following product:*

*Le produit désigné ci-dessous:*

<b>Bezeichnung:</b>	<b>"Ex" Ultraschall-Laufzeitsensoren</b>
<i>Description:</i>	<i>"Ex" ultrasonic transit time sensors</i>
<i>Désignation:</i>	<i>"Ex" capteurs ultrasoniques temps de transit</i>
<b>Typ / Type:</b>	<b>NIS-V2xxRxExxxx / NIS-V280KxExxxx / NIS0V200RLExxxx / TSP0V200RLExxMx</b>

erklären wir in alleiniger Verantwortung, dass die auf dem Unionsmarkt ab dem Zeitpunkt der Unterzeichnung bereitgestellten Geräte die folgenden einschlägigen Harmonisierungsvorschriften der Union erfüllen:

*we declare under our sole responsibility that the equipment made available on the Union market as of the date of signature of this document meets the standards of the following applicable Union harmonisation legislation:*

*nous déclarons, sous notre seule responsabilité, à la date de la présente signature, la conformité du produit pour le marché de l'Union, aux directives d'harmonisation de la législation au sein de l'Union:*

- 2014/30/EU
- 2014/34/EU
- 2011/65/EU

Bei der Bewertung wurden folgende einschlägige harmonisierte Normen zugrunde gelegt bzw. wird die Konformität erklärt in Bezug auf die nachfolgend genannten anderen technischen Spezifikationen:

*The evaluation assessed the following applicable harmonised standards or the conformity is declared in relation to other technical specifications listed below:*

*L'évaluation est effectuée à partir des normes harmonisées applicable ou la conformité est déclarée en relation aux autres spécifications techniques désignées ci-dessous:*

- EN 61326-1:2013
- EN IEC 60079-0:2018/AC:2020-02
- EN 60079-11:2012

Ex-Kennzeichnung / *Ex-designation / Marquage Ex:*

II 2G Ex ib IIB T4 Gb

EU-Baumusterprüfbescheinigung / *EU-Type Examination Certificate / Attestation d'examen «UE» de type:*

TÜV 12 ATEX 087812 ISSUE: 02

Notifizierte Stelle (Kennnummer) / *Notified Body (Identif. No.) / Organisme notifié (N° d'identification)*

TÜV Nord CERT GmbH, Am TÜV 1, 45307 Essen, Germany

(0044)

Diese Erklärung wird verantwortlich für den Hersteller:

*This declaration is submitted on behalf of the manufacturer:*

*Le fabricant assume la responsabilité de cette déclaration:*

**NIVUS GmbH**  
**Im Taele 2**  
**75031 Eppingen**  
**Germany**

abgegeben durch / *represented by / faite par:*

**Marcus Fischer** (Geschäftsführer / *Managing Director / Directeur général*)

Eppingen, den 19.12.2025

Gez. *Marcus Fischer*

DE/EN/FR

## EU Konformitätserklärung

*EU Declaration of Conformity*

*Déclaration de conformité UE*

Für das folgend bezeichnete Erzeugnis.

*For the following product:*

*Le produit désigné ci-dessous:*



NIVUS GmbH  
Im Täle 2  
75031 Eppingen

Telefon: +49 07262 9191-0  
Telefax: +49 07262 9191-999  
E-Mail: info@nivus.com  
Internet: www.nivus.de

<b>Bezeichnung:</b>	<b>Clamp-On Ultraschall-Laufzeitdifferenz-Sensoren</b>
<i>Description:</i>	<i>ultrasonic clamp-on sensors</i>
<i>Désignation:</i>	<i>capteurs ultrasoniques Clamp-On</i>
<b>Typ / Type:</b>	<b>NIC-CO...</b>

erklären wir in alleiniger Verantwortung, dass die auf dem Unionsmarkt ab dem Zeitpunkt der Unterzeichnung bereitgestellten Geräte die folgenden einschlägigen Harmonisierungsvorschriften der Union erfüllen:

*we declare under our sole responsibility that the equipment made available on the Union market as of the date of signature of this document meets the standards of the following applicable Union harmonisation legislation:*

*nous déclarons, sous notre seule responsabilité, à la date de la présente signature, la conformité du produit pour le marché de l'Union, aux directives d'harmonisation de la législation au sein de l'Union:*

- 2014/30/EU
- 2011/65/EU

Bei der Bewertung wurden folgende einschlägige harmonisierte Normen zugrunde gelegt bzw. wird die Konformität erklärt in Bezug die nachfolgend genannten anderen technischen Spezifikationen:

*The evaluation assessed the following applicable harmonised standards or the conformity is declared in relation to other technical specifications listed below:*

*L'évaluation est effectuée à partir des normes harmonisées applicable ou la conformité est déclarée en relation aux autres spécifications techniques désignées ci-dessous:*

- EN 61326-1-2013

Diese Erklärung wird verantwortlich für den Hersteller:

*This declaration is submitted on behalf of the manufacturer:*

*Le fabricant assume la responsabilité de cette déclaration:*

**NIVUS GmbH**  
**Im Täle 2**  
**75031 Eppingen**  
**Allemagne**

abgegeben durch / *represented by / faite par:*

**Marcus Fischer** (Geschäftsführer / *Managing Director / Directeur général*)

Eppingen, den 14.07.2017

Gez. *Marcus Fischer*

DE/EN/FR



## EU Konformitätserklärung

*EU Declaration of Conformity*

*Déclaration de conformité UE*

NIVUS GmbH  
Im Tæle 2  
75031 Eppingen

Telefon: +49 07262 9191-0  
Telefax: +49 07262 9191-999  
E-Mail: info@nivus.com  
Internet: www.nivus.de

Für das folgend bezeichnete Erzeugnis:

*For the following product:*

*Le produit désigné ci-dessous:*

<b>Bezeichnung:</b>	<b>"Ex" Clamp-On Ultraschall-Laufzeitdifferenz-Sensoren</b>
<i>Description:</i>	<i>"Ex" ultrasonic clamp-on sensors</i>
<i>Désignation:</i>	<i>"Ex" capteurs ultrasoniques Clamp-on</i>
<b>Typ / Type:</b>	<b>NIC-COxxE...</b>

erklären wir in alleiniger Verantwortung, dass die auf dem Unionsmarkt ab dem Zeitpunkt der Unterzeichnung bereitgestellten Geräte die folgenden einschlägigen Harmonisierungsvorschriften der Union erfüllen:

*we declare under our sole responsibility that the equipment made available on the Union market as of the date of signature of this document meets the standards of the following applicable Union harmonisation legislation:*

*nous déclarons, sous notre seule responsabilité, à la date de la présente signature, la conformité du produit pour le marché de l'Union, aux directives d'harmonisation de la législation au sein de l'Union:*

- 2014/30/EU
- 2014/34/EU
- 2011/65/EU

Bei der Bewertung wurden folgende einschlägige harmonisierte Normen zugrunde gelegt bzw. wird die Konformität erklärt in Bezug auf die nachfolgend genannten anderen technischen Spezifikationen:

*The evaluation assessed the following applicable harmonised standards or the conformity is declared in relation to other technical specifications listed below:*

*L'évaluation est effectuée à partir des normes harmonisées applicable ou la conformité est déclarée en relation aux autres spécifications techniques désignées ci-dessous:*

- EN 61326-1:2013
- EN IEC 60079-0:2018/AC:2020-2
- EN 60079-11:2012

Ex-Kennzeichnung / *Ex-designation* / *Marquage Ex* :

Ⓔ II 2G Ex ib IIB T4 Gb

EU-Baumusterprüfbescheinigung / *EU-Type Examination Certificate* / *Attestation d'examen «UE» de type:*

TÜV 12 ATEX 087812 ISSUE: 02

Notifizierte Stelle (Kennnummer) / *Notified Body (Identif. No.)* / *Organisme notifié (N° d'identification)*

TÜV Nord CERT GmbH, Am TÜV 1, 45307 Essen, Germany

(0044)

Diese Erklärung wird verantwortlich für den Hersteller:

*This declaration is submitted on behalf of the manufacturer:*

*Le fabricant assume la responsabilité de cette déclaration:*



**NIVUS GmbH**  
**Im Tæle 2**  
**75031 Eppingen**  
**Germany**

abgegeben durch / *represented by* / *faite par:*

**Marcus Fischer** (Geschäftsführer / *Managing Director* / *Directeur général*)

Eppingen, den 19.12.2025

Gez. *Marcus Fischer*

**Translation**

(1) **EU-Type Examination Certificate**

(2) Equipment and protective systems intended for use in potentially explosive atmospheres, **Directive 2014/34/EU**

(3) **Certificate Number** TÜV 12 ATEX 087812 **Issue:** 02

(4) for the product: System "Sensor Family Mini" consisting of the components according to schedule

(5) of the manufacturer: **NIVUS GmbH**

(6) Address: Im Täle 2  
75031 Eppingen  
Germany

Order number: 8003076150  
Date of issue: See date of signature

(7) The design of this product and any acceptable variation thereto are specified in the schedule to this EU-Type Examination Certificate and the documents therein referred to.

(8) The TÜV NORD CERT GmbH, Notified Body No. 0044, in accordance with Article 17 of the Directive 2014/34/EU of the European Parliament and the Council of 26 February 2014, certifies that this product has been found to comply with the Essential Health and Safety Requirements relating to the design and construction of products intended for use in potentially explosive atmospheres given in Annex II to the Directive.  
The examination and test results are recorded in the confidential ATEX Assessment Report No. 24 203 381521.

(9) Compliance with the Essential Health and Safety Requirements has been assured by compliance with:  
**EN IEC 60079-0:2018/AC:2020-02** **EN 60079-11:2012**  
except in respect of those requirements listed at item 18 of the schedule.

(10) If the sign "X" is placed after the certificate number, it indicates that the product is subject to the Specific Conditions for Use specified in the schedule to this certificate.

(11) This EU-Type Examination Certificate relates only to the design, and construction of the specified product. Further requirements of the Directive apply to the manufacturing process and supply of this equipment. These are not covered by this certificate.

(12) The marking of the product shall include the following:  
 **II 2 G Ex ib IIB T4 Gb**

TÜV NORD CERT GmbH, Am TÜV 1, 45307 Essen, notified by the central office of the countries for safety engineering (ZLS), Ident. Nr. 0044, legal successor of the TÜV NORD CERT GmbH & Co. KG Ident. Nr. 0032

The deputy head of the notified body

**TUVNORD** Digital unterschrieben von Meyer  
Andreas  
Datum: 2025.07.16 08:01:03 +02'00'

Hanover office, Am TÜV 1, 30519 Hannover, Tel. +49 511 998-61455, Fax +49 511 998-61590

This certificate may only be reproduced without any change, schedule included.  
Excerpts or changes shall be allowed by the TÜV NORD CERT GmbH

P17-F-011 Rev. 02/11.21 Page 1/7



(13) **SCHEDULE**

(14) **EU-Type Examination Certificate No. TÜV 12 ATEX 087812** **Issue 02**

(15) **Description of product:**

In conjunction with the belonging measuring transducers resp. Ex-Separator-Module, the system "Sensor Family Mini" is used for measurement of the flow speed and the flow level in partly or fully filled pipes and channels via supersonic technology.

The system "Sensor Family Mini" consists of the following components:

- Electronic-Box-Mini EBM type V1L1 or type V3L1
- Sensors type:
  - Correlation sensor CSM-V100, CSM-V1D0, CSM-V100Rx, CSP-V2xx,
  - Distance sensor DSM-L0 and level sensor OCL-LM,
  - Clamp-on sensor NIC-CO,
  - Transit time sensor NIS0 V200, TSP0 V200, NIS-V200 and NIS-V280

**Type code:**

Electronic-Box-Mini EBM	Sensors	
Type V1L1 or Type V3L1	Correlation sensor	Type CSM-V100, CSM-V1D0, CSM-V100Rx, CSP-V2xx
	Distance sensor	Type DSM-L0 und Füllstandsensor OCL-LM
	Clamp-on sensor	Type NIC-CO
	Transit time sensor	Type NIS0 V200, TSP0 V200, NIS-V200 und NIS-V280

EBM	Type			Electronic-Box-Mini for connecting for connecting 1 x CSM and 1 x DSM sensor
	V1L1 V3L1			Internal construction with POA-V2 sensor generation <b>Internal construction with POA-V3 sensor generation</b>
		Design		
		RD		Standard design
		xx		Special design
		ATEX- Approval		
		0		Without
		E		ATEX-Approval Zone 1
		Cable length (max. 150 m)		
		03		3 m
		10		10 m
		99		100 m
		xx		Special length
			K	Cable end pre-assembled for connection to the NivuFlow 750 and NivuFlow 7550 transmitters via the Ex-Separator-Module iXT0

This certificate may only be reproduced without any change, schedule included.  
Excerpts or changes shall be allowed by the TÜV NORD CERT GmbH



**Schedule to EU-Type Examination Certificate No. TÜV 12 ATEX 087812 Issue 02**

**Electrical data:**

System "Sensor Family Mini" with the Elektronik-Box-Mini EBM type V1L1:

Signal- and supply circuit (Cable tail;	In type of protection intrinsic safety Ex ib IIB
Connection wires:	Only for connection to certified intrinsically safe circuits.
Red (X6): +	Maximum values:
Blue (X8): GND)	$U_i = 10.5 \text{ V}$
	$I_i = 640 \text{ mA}$
	$P_i = 6.72 \text{ W}$
	Effective internal capacitance $C_i$ = Capacitance of the permanently connected Cable = $90 \text{ pF/m} \times L^*$
	Effective internal inductance $L_i$ = Inductance of the permanently connected Cable = $0.76 \text{ } \mu\text{H/m} \times L^*$

L\*: Length of the connected Cable has to not exceed 150 m.

The connection to the following measuring transducers of the manufacturer NIVUS is permissible:

- Type OCP-... according to TÜV 00 ATEX 1572 or
- Type PCP-... according to TÜV 03 ATEX 2268 or
- Type IXT0-... according to TÜV 14 ATEX 142076

Connection wire black (X10)	Shield
RS485 interface (Cable tail;	In type of protection intrinsic safety Ex ib IIB with maximum values:
Connection wires:	$U_o = 6 \text{ V}$
White (X14): RxTx+	$I_o = 81.9 \text{ mA}$ (long time; for calculation of $P_o$ )
Green (X13): RxTx-	$I_o = 154 \text{ mA}$ (short time; for calculation of $L_o$ , $C_o$ )
Blue (X8): GND)	$P_o = 123 \text{ mW}$
	Characteristic line: Linear
	Effective internal capacitance $C_i = 10.5 \text{ nF}$
	Effective internal inductance $L_i = 117 \text{ } \mu\text{H}$

The maximum permissible values for the external inductance  $L_o$  and the external capacitance  $C_o$  can be found in the following table:

Ex ib IIB	$L_o$ [mH]	12.88	9.88	0.38	0.083
	$C_o$ [ $\mu\text{F}$ ]	7.08	8.38	21.98	29.98

At connection of the RS485 interface to belonging measuring transducers with active intrinsically safe circuits, the rules for the interconnection of intrinsically safe circuits have to be observed.

Or

This certificate may only be reproduced without any change, schedule included.  
Excerpts or changes shall be allowed by the TÜV NORD CERT GmbH



**Anlage zur EU-Baumusterprüfbescheinigung Nr. TÜV 12 ATEX 087812 Ausgabe 02**

Schnittstelle RS485 (Kabelschwanz; Anschlussadern: Weiß (X14): RxTx+ Grün (X13): RxTx- Blau (X8): GND)	Höchstwerte: $U_i = 12,06 \text{ V}$ $I_i = 176 \text{ mA}$ $P_i = 531 \text{ mW}$ Wirksame innere Kapazität $C_c$ = Kapazität des fest angeschlossenen Kabels $C_c$ $C_c = 70 \text{ pF/m} \times L^*$ Wirksame innere Induktivität $L_c$ = Induktivität des fest angeschlossenen Kabels $L_c$ $L_c = 0,78 \text{ } \mu\text{H/m} \times L^*$
---	---

L\*: Länge des Kabelanschlusses darf 150 m nicht überschreiten.

Der interne Druckdosen-Stromkreis (X1..X4) und der Temperaturstromkreis (X12;X5;X7) sind in der Zündschutzart Eigensicherheit Ex ib IIB ausgeführt und sind für den Anwender nicht zugänglich.

Die Zusammenschaltung der Elektronik-Box-Mini EBM mit den Sensoren

- Correlation-Sensor-Mini Typ CSM-V100, CSM-V1D0, CSM-V100Rx und CSP- V2xx und
- Distance-Sensor-Mini Typ DSM (oder Füllstandssensor Typ OCL-LM)

über eine 20 m lange Leitung des Herstellers ist zulässig.

Piezo Anschlüsse (Anschluss-Pins A/B oder C/D)	In Zündschutzart Eigensicherheit Ex ib IIB Nur zum Anschluss an die eigensicheren Stromkreise der Geräte „Elektronik-Box-Mini “ EBM oder des "NivuFlow Mobile" NFM des Herstellers mit sicherer Energiebegrenzung $C_i = 11 \text{ nF}$ $L_i = 12 \text{ } \mu\text{H}$
---	---

1-Wire Temperatur-Sensor 1-Wire EEPROM (Anschluss-Pins E, F und J)	In Zündschutzart Eigensicherheit Ex ib IIB Nur zum Anschluss an bescheinigte eigensichere Stromkreise Höchstwerte: $U_i = 6 \text{ V}$ $I_i = 188 \text{ mA}$ $P_i = 282 \text{ mW}$ Wirksame innere Kapazität $C_i = 120 \text{ nF}$ Wirksame innere Induktivität ist vernachlässigbar klein.
--	--

Druckdose (Anschluss-Pins E, G, H und J)	In Zündschutzart Eigensicherheit Ex ib IIB Nur zum Anschluss an bescheinigte eigensichere Stromkreise Höchstwerte: $U_i = 6 \text{ V}$ $I_i = 264 \text{ mA}$ $P_i = 396 \text{ mW}$ Wirksame innere Kapazität $C_i = 6,484 \text{ } \mu\text{F}$ Wirksame innere Induktivität ist vernachlässigbar klein.
---	--

Alle eigensicheren Stromkreise sind galvanisch miteinander über das GND-Potential verbunden und sicher galvanisch vom Erdpotential getrennt.

Diese Bescheinigung darf nur unverändert weiterverbreitet werden.  
 Auszüge oder Änderungen bedürfen der Genehmigung der TÜV NORD CERT GmbH



**Schedule to EU-Type Examination Certificate No. TÜV 12 ATEX 087812 Issue 02**

**System "Sensor Family Mini" with the Elektronik-Box-Mini EBM type V3L1:**

Signal- and supply circuit (Cable tail; Connection wires: Red (X1): + Blue (X2): GND)	In type of protection intrinsic safety Ex ib IIB Only for connection to certified intrinsically safe circuits. Maximum values: $U_i = 10.5 \text{ V}$ $I_i = 640 \text{ mA}$ $P_i = 6.72 \text{ W}$ Effective internal capacitance $C_i = 2.2 \mu\text{F} +$ Capacitance of the permanently connected Cable $= 2.2 \mu\text{F} + 90 \text{ pF/m} \times L^*$ Effective internal inductance $L_i = 4.7 \mu\text{H} +$ Inductance of the permanently connected Cable = $4.7 \mu\text{H} + 0.76 \mu\text{H/m} \times L^*$
---	---

$L^*$ : Length of the connected Cable has to not exceed 150 m.

The connection to the following measuring transducers of the manufacturer NIVUS is permissible:

Type OCP-... according to TÜV 00 ATEX 1572 or  
Type PCP-... according to TÜV 03 ATEX 2268 or  
Type IXTO-... according to TÜV 14 ATEX 142076

Connection wire black (X3)	Shield
RS485 interface (Cable tail; Connection wires: White (X5): RxTx+ Green (X4): RxTx- Blue (X2): GND)	In type of protection intrinsic safety Ex ib IIB with maximum values: $U_o = 5.4 \text{ V}$ $I_o = 76 \text{ mA}$ (long time; for calculation of $P_n$ ) $I_o = 124.93 \text{ mA}$ (short time; for calculation of $L_o, C_o$ ) $P_o = 102.6 \text{ mW}$ Characteristic line: Linear Effective internal capacitance $C_i = 10.5 \text{ nF}$ Effective internal inductance $L_i = 117 \mu\text{H}$

The maximum permissible values for the external inductance  $L_o$  and the external capacitance  $C_o$  can be found in the following table:

<b>Ex ib IIB</b>	$L_o$ [mH]	19.88	9.88	0.38	0.08
	$C_o$ [ $\mu\text{F}$ ]	7.98	11.98	27.98	36.98

At connection of the RS485 interface to belonging measuring transducers with active intrinsically safe circuits, the rules for the interconnection of intrinsically safe circuits have to be observed.

Or

This certificate may only be reproduced without any change, schedule included.  
Excerpts or changes shall be allowed by the TÜV NORD CERT GmbH



**Schedule to EU-Type Examination Certificate No. TÜV 12 ATEX 087812 Issue 02**

RS485 interface (Cable tail; Connection wires: White (X5): RxTx+ Green (X4): RxTx- Blue (X2): GND)	Maximum values: $U_i = 10.7 \text{ V}$ $I_i = 236.3 \text{ mA}$ $P_i = 634.4 \text{ mW}$ Effective internal capacitance $C_i =$ Capacitance of the permanently connected Cable $C_c$ $C_c = 70 \text{ pF/m} \times L^*$ Effective internal inductance $L_i = 1.5 \text{ mH} +$ Inductance of the permanently connected Cable $L_c$ $L_c = 1.5 \text{ mH} + 0.78 \text{ } \mu\text{H/m} \times L^*$
---	---

$L^*$ : Length of the connected Cable has to not exceed 150 m.

The internal pressure circuit (X6..X9) and temperature circuit (X10;X11;X12) are designed in type of protection intrinsic safety Ex ib IIB and are not accessible to the user.

The interconnection of the Electronic-Box-Mini EBM with the sensors

- Correlation sensor Mini type CSM-V100 or CSM-V1D0 or CSM-V100Rx or CSP-V2xx and
  - Distance sensor Mini type DSM (or filling level sensor type OCL-LM)
- via a Cable of the manufacturer with a length of 20 m is permissible.

Piezo connections (Connector Pins A/B or C/D)	In type of protection Intrinsic Safety Ex ib IIB Only for connection to the intrinsically safe circuits of the devices "Electronic-Box-Mini" EBM or the "NivuFlow Mobile" NFM of the manufacturer with safe energy limitation $C_i = 11 \text{ nF}$ $L_i = 12 \text{ } \mu\text{H}$
--	---

1-Wire temperature sensor 1-Wire EEPROM (Connector Pins E, F and J)	In type of protection Intrinsic Safety Ex ib IIB Only for connection to certified intrinsically safe circuits. Maximum values: $U_i = 6 \text{ V}$ $I_i = 188 \text{ mA}$ $P_i = 282 \text{ mW}$ Effective internal capacitance $C_i = 120 \text{ nF}$ Effective internal inductance is negligibly small.
---	---

Pressure cell (Connector Pins E, G, H and J)	In type of protection Intrinsic Safety Ex ib IIB Only for connection to certified intrinsically safe circuits. Maximum values: $U_i = 6 \text{ V}$ $I_i = 264 \text{ mA}$ $P_i = 396 \text{ mW}$ Effective internal capacitance $C_i = 6.484 \text{ } \mu\text{F}$ Effective internal inductance is negligibly small.
---	---

All intrinsically safe circuits are galvanically interconnected with each other via GND potential and safely galvanically separated from earth potential.

This certificate may only be reproduced without any change, schedule included.  
 Excerpts or changes shall be allowed by the TÜV NORD CERT GmbH



**Schedule to EU-Type Examination Certificate No. TÜV 12 ATEX 087812 Issue 02**

**Thermal data:**



Permissible ambient temperature range during operation:

- Electronic-Box-Mini EBM: -20 °C ... +40 °C
- For all Sensors: -40 °C ... +80 °C

- (16) Drawings and documents are listed in the ATEX Assessment Report No. 24 203 381521
- (17) **Specific Conditions for Use:**  
None.
- (18) **Essential Health and Safety Requirements:**  
No additional ones.

- End of EU-Type Examination Certificate -

This certificate may only be reproduced without any change, schedule included.  
Excerpts or changes shall be allowed by the TÜV NORD CERT GmbH

		<h2 style="margin: 0;">IECEX Certificate of Conformity</h2>	
<p><b>INTERNATIONAL ELECTROTECHNICAL COMMISSION</b>  <b>IEC Certification System for Explosive Atmospheres</b>  <small>for rules and details of the IECEx Scheme visit <a href="http://www.iecex.com">www.iecex.com</a></small></p>			
Certificate No.:	<b>IECEX TUN 18.0023</b>	Page 1 of 4	<a href="#">Certificate history:</a>
Status:	<b>Current</b>	Issue No: 2	<a href="#">Issue 1 (2019-05-10)</a> <a href="#">Issue 0 (2018-11-20)</a>
Date of Issue:	2025-07-16		
Applicant:	<b>NIVUS GmbH</b> Im Täle 2 75031 Eppingen Germany		
Equipment:	<b>System "Sensor Family Mini"; see schedule for details</b>		
Optional accessory:			
Type of Protection:	<b>Intrinsic Safety "i"</b>		
Marking:	<b>Ex ib IIB T4 Gb</b>		
<p>Approved for issue on behalf of the IECEx Certification Body:</p> <p>Position:</p> <p>Signature: (for printed version)</p> <p>Date: (for printed version)</p>		<p style="text-align: center;"><b>Andreas Meyer</b></p> <p style="text-align: center;"><b>Deputy Head of the IECEx Certification Body</b></p> <p style="text-align: center;"><b>TUVNORD</b></p> <p>Digital unterschrieben von Meyer Andreas Datum: 2025.07.16 09:45:16 +02'00'</p>	
<p>1. This certificate and schedule may only be reproduced in full.                  2. This certificate is not transferable and remains the property of the issuing body.                  3. The Status and authenticity of this certificate may be verified by visiting <a href="http://www.iecex.com">www.iecex.com</a> or use of this QR Code.</p>			
<p>Certificate issued by:</p> <p><b>TÜV NORD CERT GmbH</b> Hanover Office Am TÜV 1, 30519 Hannover Germany</p>			



## IECEX Certificate of Conformity

---

Certificate No.:	<b>IECEX TUN 18.0023</b>	Page 2 of 4
Date of issue:	2025-07-16	Issue No: 2

Manufacturer: **NIVUS GmbH**  
Im Tále 2  
75031 Eppingen  
Germany

Manufacturing locations:

This certificate is issued as verification that a sample(s), representative of production, was assessed and tested and found to comply with the IEC Standard list below and that the manufacturer's quality system, relating to the Ex products covered by this certificate, was assessed and found to comply with the IECEX Quality system requirements. This certificate is granted subject to the conditions as set out in IECEX Scheme Rules, IECEX 02 and Operational Documents as amended

**STANDARDS :**  
The equipment and any acceptable variations to it specified in the schedule of this certificate and the identified documents, was found to comply with the following standards

[IEC 60079-0:2017](#)    Explosive atmospheres - Part 0: Equipment - General requirements  
Edition: 7.0

[IEC 60079-11:2011](#)    Explosive atmospheres - Part 11: Equipment protection by intrinsic safety "i"  
Edition: 6.0

This Certificate **does not** indicate compliance with safety and performance requirements other than those expressly included in the Standards listed above.

**TEST & ASSESSMENT REPORTS:**  
A sample(s) of the equipment listed has successfully met the examination and test requirements as recorded in:

Test Report:  
[DE/TUN/EXTR18.0026/02](#)

Quality Assessment Report:  
[DE/TUN/QAR13.0011/10](#)



## IECEX Certificate of Conformity

Certificate No.: **IECEX TUN 18.0023**

Page 3 of 4

Date of issue: **2025-07-16**

Issue No: **2**

### **EQUIPMENT:**

Equipment and systems covered by this Certificate are as follows:

In conjunction with the belonging measuring transducers resp. Ex-Separator-Module, the system "Sensor Family Mini" is used for measurement of the flow speed and the flow level in partly or fully filled pipes and channels via supersonic technology.

The system "Sensor Family Mini" consists of the following components:

Electronic Box Mini type EBM

Sensors type

correlation sensor CSM-V100, CSM-V1D0,

CSM-V100Rx, CSP-V2xx,

distance sensor DSM-L0 and level sensor OCL-LM,

clamp-on sensor NIC-CO,

transit time sensor NIS0 V200, TSP0 V200, NIS-V200 and NIS-V280

The permissible ambient temperature range is:

For EBM: -20 °C ... 40 °C

For all sensors: -40 °C ... 80 °C

For further details see Attachment to IECEX TUN 18.0023X issue No.2

**SPECIFIC CONDITIONS OF USE: NO**



## IECEX Certificate of Conformity

---

Certificate No.:	IECEX TUN 18.0023	Page 4 of 4
Date of issue:	2025-07-16	Issue No: 2

**DETAILS OF CERTIFICATE CHANGES (for issues 1 and above)**  
The subject of IECEX TUN 18.0023 issue No.2 is the use of the new POA-V3 sensor electronics (IECEX TUN 15.0014 Issue 2) within the Electronic-Box-Mini EBM, new Ex add-on PCB, new front panel PCB and update to the standards IEC 60079-0:2017 and IEC 60079-11:2011

IECEX TUN 18.0023 issue No.1  
Electronic-Box-Mini EBM type V1L1  
Internal construction with POA-V2 sensor generation

IECEX TUN 18.0023 issue No.2  
Electronic-Box-Mini EBM type V3L1  
Internal construction with POA-V3 sensor generation

Note: All outputs are linear due to the electronic changes.

**Annex:**

[Attachment to IECEX TUN 18.0023 issue No.2.pdf](#)

TÜV NORD CERT GmbH  
 Hannover Office  
 Am TÜV 1  
 30519 Hannover  
 Germany



Page 1 of 5  
 Attachment to IECEx TUN 18.0023 issue No.: 2

**General product information:**

**Description:**

In conjunction with the belonging measuring transducers resp. Ex-Separator-Module, the system "Sensor Family Mini" is used for measurement of the flow speed and the flow level in partly or fully filled pipes and channels via supersonic technology.

The system "Sensor Family Mini" consists of the following components:

- Electronic-Box-Mini EBM type V1L1 or type V3L1
- Sensors type:
  - Correlation sensor CSM-V100, CSM-V1D0, CSM-V100Rx, CSP-V2xx.
  - Distance sensor DSM-L0 and level sensor OCL-LM,
  - Clamp-on sensor NIC-CO,
  - Transit time sensor NIS0 V200, TSP0 V200, NIS-V200 and NIS-V280

**Type code:**

Electronic-Box-Mini EBM	Sensors	
Type V1L1 or Type V3L1	Correlation sensor	Type CSM-V100, CSM-V1D0, CSM-V100Rx, CSP-V2xx
	Distance sensor	Type DSM-L0 und Füllstandsensor OCL-LM
	Clamp-on sensor	Type NIC-CO
	Transit time sensor	Type NIS0 V200, TSP0 V200, NIS-V200 und NIS-V280

EBM	Type		
			Electronic-Box-Mini for connecting for connecting 1 x CSM and 1 x DSM sensor
	V1L1		Internal construction with POA-V2 sensor generation
	V3L1		<b>Internal construction with POA-V3 sensor generation</b>
		Design	
		RD	Standard design
		xx	Special design
		IECEx- Approval	
		0	Without
		E	IECEx-Approval Zone 1
		Cable length (max. 150 m)	
		03	3 m
		10	10 m
		99	100 m
		xx	Special length
		K	Cable end pre-assembled for connection to the NivuFlow 750 and NivuFlow 7550 transmitters via the Ex-Separator-Module iXT0

P17-F-810

Rev. 01 / 06.18

TÜV NORD CERT GmbH  
Hannover Office  
Am TÜV 1  
30519 Hannover  
Germany



Page 2 of 5  
Attachment to IECEx TUN 18.0023 issue No.: 2

**Electrical data:**

System "Sensor Family Mini" with the Electronic-Box-Mini EBM type V1L1:

Signal- and supply circuit (Cable tail;	In type of protection intrinsic safety Ex ib IIB Only for connection to certified intrinsically safe circuits.
Connection wires:	Maximum values:
Red (X6): +	$U_i = 10.5 \text{ V}$
Blue (X8): GND)	$I_i = 640 \text{ mA}$
	$P_i = 6.72 \text{ W}$
	Effective internal capacitance $C_i$ = Capacitance of the permanently connected cable = $90 \text{ pF/m} \times L^*$
	Effective internal inductance $L_i$ = Inductance of the permanently connected cable = $0.76 \text{ } \mu\text{H/m} \times L^*$

$L^*$ : Length of the connected cable has to not exceed 150 m.

The connection to the measuring transducer type IXT0-xxx (IECEx TUN 14.0014) of the manufacturer NIVUS is permissible.

Connection wire black (X10)	Shield
RS485 interface (Cable tail;	In type of protection intrinsic safety Ex ib IIB with maximum values:
Connection wires:	$U_o = 6 \text{ V}$
White (X14): RxTx+	$I_o = 81.9 \text{ mA}$ (long time; for calculation of $P_o$ )
Green (X13): RxTx-	$I_o = 154 \text{ mA}$ (short time; for calculation of $L_o, C_o$ )
Blue (X8): GND)	$P_o = 123 \text{ mW}$
	Characteristic line: Linear
	Effective internal capacitance $C_i = 10.5 \text{ nF}$
	Effective internal inductance $L_i = 117 \text{ } \mu\text{H}$

The maximum permissible values for the external inductance  $L_o$  and the external capacitance  $C_o$  can be found in the following table:

Ex ib IIB	$L_o$ [mH]	12.88	9.88	0.38	0.083
	$C_o$ [ $\mu\text{F}$ ]	7.08	8.38	21.98	29.98

At connection of the RS485 interface to belonging measuring transducers with active intrinsically safe circuits, the rules for the interconnection of intrinsically safe circuits have to be observed.

Or

RS485 interface (Cable tail;	Maximum values:
Connection wires:	$U_i = 12.06 \text{ V}$
White (X14): RxTx+	$I_i = 176 \text{ mA}$
Green (X13): RxTx-	$P_i = 531 \text{ mW}$
Blue (X8): GND)	Effective internal capacitance $C_i$ = Capacitance of the permanently connected cable $C_c$
	$C_c = 70 \text{ pF/m} \times L^*$
	Effective internal inductance $L_i$ = Inductance of the permanently connected cable $L_c$
	$L_c = 0.78 \text{ } \mu\text{H/m} \times L^*$

$L^*$ : Length of the connected cable has to not exceed 150 m.

The internal pressure circuit (X1..X4) and temperature circuit (X12;X5;X7) are designed in type of protection intrinsic safety Ex ib IIB and are not accessible to the user.

**TÜV NORD CERT GmbH**  
**Hannover Office**  
**Am TÜV 1**  
**30519 Hannover**  
**Germany**



**Page 3 of 5**  
**Attachment to IECEx TUN 18.0023 issue No.: 2**

The interconnection of the Electronic-Box-Mini EBM with the sensors

- Correlation sensor Mini type CSM-V100 or CSM-V1D0 or CSM-V100Rx or CSP-V2xx and
- Distance sensor Mini type DSM (or filling level sensor type OCL-LM)

via a cable of the manufacturer with a length of 20 m is permissible.

Piezo connections (Connector Pins A/B or C/D)	In type of protection Intrinsic Safety Ex ib IIB Only for connection to the intrinsically safe circuits of the devices "Electronic-Box-Mini" EBM or the "NivuFlow Mobile" NFM of the manufacturer with safe energy limitation: C <sub>i</sub> = 11 nF L <sub>i</sub> = 12 µH
1-Wire temperature sensor 1-Wire EEPROM (Connector Pins E, F and J)	In type of protection Intrinsic Safety Ex ib IIB Only for connection to certified intrinsically safe circuits: Maximum values: U <sub>i</sub> = 6 V I <sub>i</sub> = 188 mA P <sub>i</sub> = 282 mW Effective internal capacitance C <sub>i</sub> = 120 nF Effective internal inductance is negligibly small.
Pressure cell (Connector Pins E, G, H and J)	In type of protection Intrinsic Safety Ex ib IIB Only for connection to certified intrinsically safe circuits: Maximum values: U <sub>i</sub> = 6 V I <sub>i</sub> = 264 mA P <sub>i</sub> = 396 mW Effective internal capacitance C <sub>i</sub> = 6.484 µF Effective internal inductance is negligibly small.

All intrinsically safe circuits are galvanically interconnected with each other via GND potential and safely galvanically separated from earth potential.

System "Sensor Family Mini" with the Electronic-Box-Mini EBM type V3L1:

Signal- and supply circuit (Cable tail; Connection wires: Red (X1): + Blue (X2): GND)	In type of protection intrinsic safety Ex ib IIB Only for connection to certified intrinsically safe circuits. Maximum values: U <sub>i</sub> = 10.5 V I <sub>i</sub> = 640 mA P <sub>i</sub> = 6.72 W Effective internal capacitance C <sub>i</sub> = 2.2 µF + Capacitance of the permanently connected cable = 2.2 µF + 90 pF/m x L* Effective internal inductance L <sub>i</sub> = 4.7 µH + Inductance of the permanently connected cable = 4.7 µH + 0.76 µH/m x L*
---	---

L\*: Length of the connected cable has to not exceed 150 m.

The connection to the measuring transducer type IXT0-xxx (IECEx TUN 14.0014) of the manufacturer NIVUS is permissible.

Connection wire black (X3)	Shield
----------------------------	--------

TÜV NORD CERT GmbH  
Hannover Office  
Am TÜV 1  
30519 Hannover  
Germany



Page 4 of 5  
Attachment to IECEx TUN 18.0023 issue No.: 2

RS485 interface (Cable tail; Connection wires: White (X5): RxTx+ Green (X4): RxTx- Blue (X2): GND)	In type of protection intrinsic safety Ex ib IIB with maximum values: $U_o = 5.4 \text{ V}$ $I_o = 76 \text{ mA}$ (long time; for calculation of $P_o$ ) $I_o = 124.93 \text{ mA}$ (short time; for calculation of $L_o$ , $C_o$ ) $P_o = 102.6 \text{ mW}$ Characteristic line: Linear Effective internal capacitance $C_i = 10.5 \text{ nF}$ Effective internal inductance $L_i = 117 \text{ }\mu\text{H}$
---	---

The maximum permissible values for the external inductance  $L_o$  and the external capacitance  $C_o$  can be found in the following table:

Ex ib IIB	$L_o$ [mH]	19.88	9.88	0.38	0.08
	$C_o$ [ $\mu\text{F}$ ]	7.98	11.98	27.98	36.98

At connection of the RS485 interface to belonging measuring transducers with active intrinsically safe circuits, the rules for the interconnection of intrinsically safe circuits have to be observed.

Or

RS485 interface (Cable tail; Connection wires: White (X5): RxTx+ Green (X4): RxTx- Blue (X2): GND)	Maximum values: $U_i = 10.7 \text{ V}$ $I_i = 236.3 \text{ mA}$ $P_i = 634.4 \text{ mW}$ Effective internal capacitance $C_i =$ Capacitance of the permanently connected cable $C_c$ $C_c = 70 \text{ pF/m} \times L^*$ Effective internal inductance $L_i = 1.5 \text{ mH} +$ Inductance of the permanently connected cable $L_c$ $L_c = 1.5 \text{ mH} + 0.78 \text{ }\mu\text{H/m} \times L^*$
---	--

$L^*$ : Length of the connected cable has to not exceed 150 m.

The internal pressure circuit (X6..X9) and temperature circuit (X10;X11;X12) are designed in type of protection intrinsic safety Ex ib IIB and are not accessible to the user.

The interconnection of the Electronic-Box-Mini EBM with the sensors

- Correlation sensor Mini type CSM-V100 or CSM-V1D0 or CSM-V100Rx or CSP-V2xx and
- Distance sensor Mini type DSM (or filling level sensor type OCL-LM)

via a cable of the manufacturer with a length of 20 m is permissible.

Piezo connections (Connector Pins A/B or C/D)	In type of protection Intrinsic Safety Ex ib IIB Only for connection to the intrinsically safe circuits of the devices "Electronic-Box-Mini" EBM or the "NivuFlow Mobile" NFM of the manufacturer with safe energy limitation: $C_i = 11 \text{ nF}$ $L_i = 12 \text{ }\mu\text{H}$
--	--

1-Wire temperature sensor 1-Wire EEPROM (Connector Pins E, F and J)	In type of protection Intrinsic Safety Ex ib IIB Only for connection to certified intrinsically safe circuits: Maximum values: $U_i = 6 \text{ V}$ $I_i = 188 \text{ mA}$ $P_i = 282 \text{ mW}$ Effective internal capacitance $C_i = 120 \text{ nF}$ Effective internal inductance is negligibly small.
---	--

TÜV NORD CERT GmbH  
 Hannover Office  
 Am TÜV 1  
 30519 Hannover  
 Germany



Page 5 of 5  
 Attachment to IECEx TUN 18.0023 issue No.: 2

Pressure cell  
 (Connector Pins E, G, H and J)

In type of protection Intrinsic Safety Ex ib IIB  
 Only for connection to certified intrinsically safe circuits.  
 Maximum values:  
 $U_i = 6\text{ V}$   
 $I_i = 264\text{ mA}$   
 $P_i = 396\text{ mW}$   
 Effective internal capacitance  $C_i = 6.484\text{ }\mu\text{F}$   
 Effective internal inductance is negligibly small.

All intrinsically safe circuits are galvanically interconnected with each other via GND potential and safely galvanically separated from earth potential.

**Thermal data:**

Permissible ambient temperature range during operation:

- Elektronik-Box-Mini type EBM:  $-20\text{ }^\circ\text{C} \dots +40\text{ }^\circ\text{C}$
- For all Sensors:  $-40\text{ }^\circ\text{C} \dots +80\text{ }^\circ\text{C}$

**Details of change:**

The subject of IECEx TUN 18.0023 issue No.2 is the use of the new POA-V3 sensor electronics (IECEX TUN 15.0014 Issue 2) within the Electronic-Box-Mini EBM, new Ex add-on PCB, new front panel PCB and update to the standards IEC 60079-0:2017 and IEC 60079-11:2011

IECEX TUN 18.0023 issue No.1	IECEX TUN 18.0023 issue No.2
Electronic-Box-Mini EBM type V1L1 Internal construction with POA-V2 sensor generation	Electronic-Box-Mini EBM type V3L1 <b>Internal construction with POA-V3 sensor generation</b>

Note: All outputs are linear due to the electronic changes.

**Specific Conditions of Use:**

None.