



NivuLink Radar

NivuLink Radar

Self-sufficient level sensor with integrated gateway for data transmission

Smart battery-powered IoT level sensor with state-of-the-art radar measurement technology. All-in-one device - sensing, batteries, and transmission in a robust housing. NB-IoT / LoRa transmission possible.

The status LED provides quick on-site system assessment. Cutting-edge OTA programming and cloud connectivity. Event-based storage and transmission cycles enable the optimal balance between data density and battery life.

High flexibility towards challenging measurement sites due to additional external antenna.

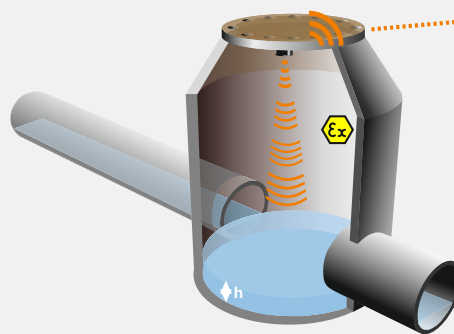

measure analyse optimise



NivuLinkRadar

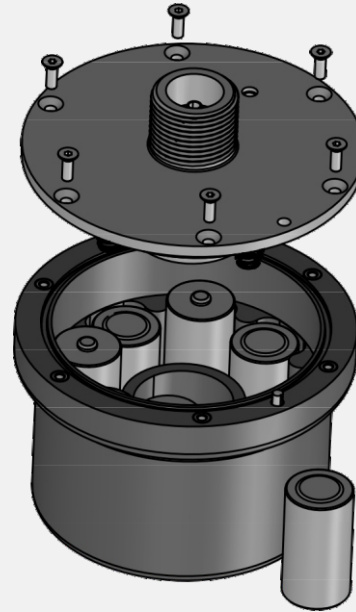
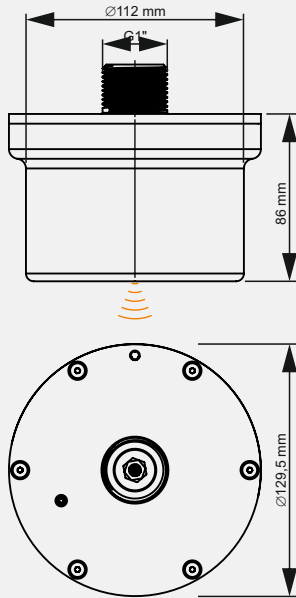

Dimensions in mm

Specifications

Measurement distance	Up to 8 m
Operation time	14 years @ 1 min/1 h (measuring cycle/data transmission) 90 years* @ 15 min/24 h (measuring cycle/data transmission) *theoretical value reagarding power consumption, components are not tested to last that long
Measurement uncertainty	+/- 2 mm
Weight	410 empty weight / 910 g (full equipt)
Protection	IP68
Measurement method	Radar, 60 GHz
Wireless technology	LTE-M, NB-IoT
Operating temperature	-15°C to +60°C
Ex approval	ATEX Zone 1

All specifications subject to technical changes

Specifications subject to change. 09.2023